

---

# ECOScience ENERGY CENTRE

## Installation and User Manual

### Top Connected System Tank

Control System: CS300

6300wt, 6500wt, 8500wt, 8750wt





## **Congratulations on choosing this ECOScience product**

*We are confident that this product will meet all your expectations, both in terms of climate comfort and energy savings. Choosing one of our products also shows your commitment and concern for our shared environment.*

*Whatever product or package you have chosen, you will be at the absolute forefront of technology in terms of efficient energy use. If you have chosen an individual energy centre such as the 6500i, this can always be used directly to produce hot tap water and radiator heating via the integrated 4.5 kW electric heaters.*

*You can add to your energy centre later with a range of add-on modules. The control system manages the add-on modules connected to the centre using module key updates and at the same time ensures optimum energy efficiency.*

*The control system is operated using a user-friendly colour touchscreen.*

*Managing Director*

*Mikael Jönsson*



## **INSTALLATION CERTIFICATE**

For warranty cover and to register the product with ECOScience.

### **PRODUCTS THAT HAVE BEEN INSTALLED:**

Name:

Product number:

Date of installation:

### **THE PRODUCTS HAVE BEEN INSTALLED AT:**

Name:

Address:

Postal address:

Telephone:

### **THE PRODUCTS WERE INSTALLED BY:**

Company:

Address:

Postal address:

Telephone:

Installation engineer:

**To be sent to:**



## TERMS OF WARRANTY

This is an extract from the ECOScience Terms of Warranty. See AA VVS 09 (general terms issued by industry associations) for full terms and conditions. If the instructions set out in this documentation are not followed, the obligations that would otherwise be incumbent upon ECOScience under these terms shall not be binding. Due to the rapid pace of development in the industry, we reserve the right to amend specifications and modify parts.

- All products marketed by ECOScience are covered by a 2 year warranty for design, manufacture and material defects that commences from the date of installation.
- For the duration of the warranty, the installation engineer undertakes to rectify any defects that occur, either by repairing and/or replacing the product.
- If the purchaser wishes to resolve any defects himself, the product must be examined beforehand by us or by a person we have appointed. A separate agreement may be entered into regarding repairs and costs.
- In the event of a defect, the installation engineer must be contacted first.
- A defect means any departure from the normal standard, assessed by an industry professional. Defects or deficiencies that occur due to abnormal circumstances, such as mechanical or environmental circumstances, shall not fall under the scope of the warranty.
- ECOScience shall therefore not be liable if the defect is attributed to abnormal or varying water quality, such as chalky or aggressive water, variations in electrical voltage or other electrical interference.
- Nor shall ECOScience be liable for defects if the installation and/or maintenance instructions have not been followed.
- The product must be examined thoroughly on delivery. Any defects discovered must be reported before the product is used. All defects must be reported immediately.
- ECOScience shall not be liable for defects that have not been reported within 2 years of the date of installation.
- ECOScience shall not be liable for 'indirect' damage/loss, including damage to entities other than the product, for example personal injury, damage to physical property or losses caused by operational stoppage etc..
- Nor shall ECOScience be liable for compensation in the event of any increase in energy consumption caused by a defect in the product or the installation. For the rest, the provisions set out in AA VVS 09 apply.
- If the product requires modification or to be serviced by a professional, consult your installation engineer who will undertake any necessary adjustments.
- When reporting defects, please state the product production number, date of installation and details of the installation engineer.

## RESPONSIBILITY

The installation engineer is responsible for ensuring that these instructions are followed and that the environment and the methods used when the control system is installed, commissioned and operated, are correct. If these instructions are ignored, costly material damage and/or serious personal injury may result.

Due to the foregoing, neither the manufacturer nor the supplier of this product shall be liable for losses, damage or other costs incurred as a result of incorrect installation and/or commissioning, operation or maintenance work.

The manufacturer and/or the supplier of this product reserves the right to amend and/or update, without notice, the composition of the product, its specifications, technical information and/or the accompanying installation and operation manual.

If the control system becomes damaged, or deficiencies are discovered that may put safety and/or operation at risk, the system must be switched off immediately and the installation engineer called in.

**This user manual forms part of the product documentation in accordance with the EU's Pressure Equipment, Electromagnetic Compatibility and Low Voltage Directives.**

This manual is intended for installation engineers and users.

The person responsible must ensure that they have read and understood the manual and the information in the included documentation. Particular attention must be paid to the sections on product and personal safety.

The manual should be kept in an easily remembered and accessible place and should be consulted even if the slightest doubt exists.

The manufacturer assumes no liability for injury to persons or animals, damage to property or damage to the product itself that occur as a result of incompetent handling, are caused by failure to adequately observe the safety instructions set out in this manual, or by modifying the product or using unsuitable spare parts.

© 2010

Copyright to the manual is held exclusively by

Fueltech Sweden AB

Fridhemsvägen 15

372 25 Ronneby, Sweden

This manual may only be reproduced or provided to a third party with written consent. This also applies if extracts from the manual are to be copied or passed on.



# Contents

<b>1</b>	<b>BASIC INFORMATION</b>	<b>1</b>
1.1	ABOUT THE MANUAL	1
1.1.1	Explanation of Warnings	1
1.1.2	Important information	2
1.1.3	Changes and updates	2
1.2	INSTALLATION ENGINEERS	2
1.3	ECOSCIENCE Energy Centre	3
1.3.1	Description	3
1.3.2	Manufacturer	3
1.4	PRODUCT MARKING	3
1.4.1	Identification plate	4
1.4.2	EC declaration of conformity	4
<b>2</b>	<b>SAFETY INSTRUCTIONS</b>	<b>5</b>
2.1	GENERAL HAZARDS	5
2.1.1	Space required	5
2.1.2	Risks involving spare parts	5
<b>3</b>	<b>DESCRIPTION OF FUNCTIONS</b>	<b>6</b>
3.1	GENERAL	6
3.1.1	System tank	7
3.1.2	Energy central unit	7
3.1.2.1	Tap water circuit	7
3.1.2.2	Solar loading circuit	7
3.1.2.3	Heat circuit	8
3.1.3	Control system	8
<b>4</b>	<b>ASSEMBLY AND INSTALLATION</b>	<b>9</b>
4.1	BEFORE USE	9
4.1.1	Safe disposal of packaging material	9
4.2	GENERAL	10
4.3	ASSEMBLING THE SUPPORT BASE AND SYSTEM TANK	11
4.3.1	Instructions	11
4.4	CONNECTING THE PIPES	12
4.4.1	Please note	12
4.4.2	Instructions	12
4.4.3	Pipe connections	13
4.5	ASSEMBLY OF TEMPERATURE SENSORS AND OVERHEAT PROTECTION	16
4.5.1	Instructions	16
4.6	ELECTRICAL INSTALLATION	17
4.6.1	Please note	17
4.6.2	Instructions	17
4.7	FILLING THE SYSTEM WITH WATER	18
4.7.1	Please note	18
4.7.2	Instructions	18
4.7.3	Connections and shut-off valves	20
4.8	EMPTYING THE SYSTEM TANK	21
4.8.1	Instructions	21

## Contents

<b>5</b>	<b>COMMISSIONING</b> .....	<b>22</b>
5.1	PREPARATIONS BEFORE STARTING .....	22
5.2	START-UP .....	22
5.3	NORMAL STOP .....	22
<b>6</b>	<b>CONTROL SYSTEM</b> .....	<b>23</b>
6.1	START SCREEN (BASIC MODEL) .....	23
6.2	SYSTEM .....	24
6.3	SETUP .....	25
6.3.1	Modules .....	25
6.3.2	Manual operation .....	26
6.3.3	Heat-up sequence .....	27
6.3.4	Display settings .....	28
6.3.5	Calibrating the touchscreen .....	28
6.3.6	Restore default values .....	29
6.3.7	System information .....	29
6.3.8	Activating DFU mode .....	29
6.3.9	Calibrating the temperature sensors .....	30
6.4	DATE/TIME .....	32
6.5	STATUS TEMP .....	32
6.6	STATUS I/O .....	33
6.6.1	Explanation of 'Status I/O' menu .....	34
6.7	LANGUAGE .....	35
6.8	ALERTS/HISTORY .....	36
6.9	HEATING .....	37
6.10	SOLAR CIRCUIT .....	38
6.11	RADIATOR CIRCUIT .....	38
6.11.1	Radiator circuit temperature curve .....	39
6.11.2	Scheduled temperature changes in radiator circuit .....	40
6.11.3	Radiator circuit holiday settings .....	41
6.12	FLOOR HEATING CIRCUIT .....	42
6.12.1	Floor heating circuit temperature curve .....	43
6.12.2	Scheduled temperature changes in floor heating circuit .....	44
6.12.3	Floor heating circuit holiday settings .....	45
6.13	SOLID FUEL .....	45
6.14	BUFFER TANK .....	45
6.15	HEAT PUMP .....	45
6.16	POOL CONTROL .....	45
<b>7</b>	<b>MAINTENANCE</b> .....	<b>46</b>
7.1	MAINTENANCE AND FUNCTION CHECKS .....	46
7.1.1	Regular maintenance to be carried out at least once a year .....	46
7.2	CLEANING .....	46
<b>8</b>	<b>SERVICING AND REPAIRS</b> .....	<b>47</b>

## Contents

<b>9 TROUBLESHOOTING</b> .....	<b>48</b>
9.1 COMMON FAULTS AND SOLUTIONS .....	48
9.2 TABLE FOR RESISTANCE TEMPERATURE SENSOR Pt 100 .....	49
9.3 ALERTS AND SOLUTIONS .....	50
9.3.1 Resetting overheat protection for electric heaters ..	50
<b>10 TECHNICAL DATA</b> .....	<b>51</b>
10.1 TECHNICAL DATA, SYSTEM TANK .....	51
10.2 TECHNICAL DATA, ENERGY CENTRAL UNIT .....	51
10.3 TECHNICAL DATA, CONTROL SYSTEM .....	52
<b>11 APPENDICES</b> .....	<b>53</b>
APPENDIX 1 - EC DECLARATION OF CONFORMITY	
APPENDIX 2 - FLOW CHART	
APPENDIX 3 - WIRING DIAGRAM AND TEMPERATURE SENSORS	
APPENDIX 4 - DEFAULT SETTINGS	
APPENDIX 5 - LIST OF COMPONENTS	



# 1 BASIC INFORMATION

## 1.1 ABOUT THE MANUAL

This manual contains instructions for installation, operation and safety and is intended for installation engineers and other users of ECOScience Energy Centre.

Read the manual carefully and make sure it is always on hand.

Failure to follow the instructions may cause serious personal injury or damage to the product.

- Take note of all the information contained in the boxes marked Danger! Warning! Caution! and Please note!
- Remember that any type of electrical equipment may be live.
- Servicing and maintenance: Servicing and maintenance must only be carried out by qualified service engineers.

### 1.1.1 Explanation of Warnings

In this manual, boxes headed Danger!, Warning!, Caution! and Please note! mean the following:

**DANGER!**

Ignoring this information could endanger life!

**WARNING!**

Ignoring this information may result in personal injury or put life at risk!

**CAUTION!**

Ignoring this information may result in minor personal injury or may damage the device!

**PLEASE NOTE!**

Information requiring particular attention!

### 1.1.2 Important information

The following requirements are mandatory:

The manual and other useful documents must be kept for the entire service life of the equipment.

This manual and other useful documents shall be regarded as part of the equipment.

If the owner changes, the manual must be passed to the new owner or user of the equipment.

The information in the manual must be updated if the product owner makes additions to this equipment or other modifications.

In the event of conversion or redesign, a new risk analysis is required. Any type of change must be approved by the product owner.

### 1.1.3 Changes and updates

If updates are implemented for the control system, the installation engineer is responsible for ensuring that the manual is also updated, i.e. that new instructions are added to the manual, replacing the old ones, which are removed and discarded.

The latest version of the installation and user manual for ECOScience Energy Centre, and any updates/new instructions for the control system are available to download from our website (<http://www.ecoscience.se/downloads.html>).

## 1.2 INSTALLATION ENGINEERS

---

ECOScience Energy Centre must only be installed by certified installation engineers who have the necessary theoretical and practical training.

After installation, the installation engineer must:

- Fill in the table with the programmed values.
- Walk through the system with the end user.
- Fill in the warranty card and installation certificate.
- Perform final inspection (including checks of all filters and system pressure).

## 1.3 ECOSCIENCE ENERGY CENTRE

---



### PLEASE NOTE: RECYCLABLE!

In the development of ECOScience products and the choice of materials used, much attention has been paid to environmental considerations. If the entire product or replacement parts are to be disposed of, these can be sorted into waste types and recycled. The ECOScience system tank is therefore fully recyclable.

### 1.3.1 Description

ECOScience is an Energy Centre designed for domestic use, which provides a complete solution for heating and hot water.



### PLEASE NOTE!

The system tank in the ECOScience Energy Centre should not be kept outdoors as sunlight may cause it to discolour

### 1.3.2 Manufacturer

#### Fueltech Sweden AB

Fridhemsvägen 15

372 25 Ronneby, Sweden

Website: [www.ecoscience.se](http://www.ecoscience.se)

## 1.4 PRODUCT MARKING

---

ECOScience carries the CE mark (*according to 'Figure 1. CE mark'*), which means it is designed, manufactured and described in keeping with EU requirements, for more information see 'APPENDIX 1 - EC DECLARATION OF CONFORMITY'.



Figure 1. CE mark

### 1.4.1 Identification plate

	
Manufacturer	Fueltech Sweden AB
Model	6500i
Product number	E65000100x
Volume/Water	520 litre
PED 97/23	Article 3.3
Voltage	400V 3N~ 50Hz
Output	9 kW
Frequency	50 Hz
Operating pressure	1.5/0.9 Max/min bar
Design temp.	85°C
P mark	SC0607-10
Certifying body	SP SITAC
Inspection body	SP
Date assembled	xx-xx-20xx
AO number	20xx-xxx
Individual number	E65000100x

Figure 2. Identification plate

### 1.4.2 EC declaration of conformity

See 'APPENDIX 1 - EC DECLARATION OF CONFORMITY'.

## 2 SAFETY INSTRUCTIONS

---

### 2.1 GENERAL HAZARDS

---

**DANGER: HIGH CENTRE OF GRAVITY!**

This product has a high centre of gravity and precautionary measures must be taken.

**DANGER: WEAK FOUNDATION!**

Make sure that the location intended to house the product will bear its weight (for more information see 'ASSEMBLING THE SUPPORT BASE AND SYSTEM TANK' on page 11).

**DANGER: RISK OF ELECTRIC SHOCK!**

Always switch off the power before any work on the energy centre starts.

**DANGER: RISK OF INJURY!**

Never put safety at risk by removing covers that are screwed in place or by disabling the safety equipment.

#### 2.1.1 Space required

For information on the space required see 'ASSEMBLING THE SUPPORT BASE AND SYSTEM TANK' on page 11.

#### 2.1.2 Risks involving spare parts

Only use original spare parts from the product supplier.

### 3 DESCRIPTION OF FUNCTIONS

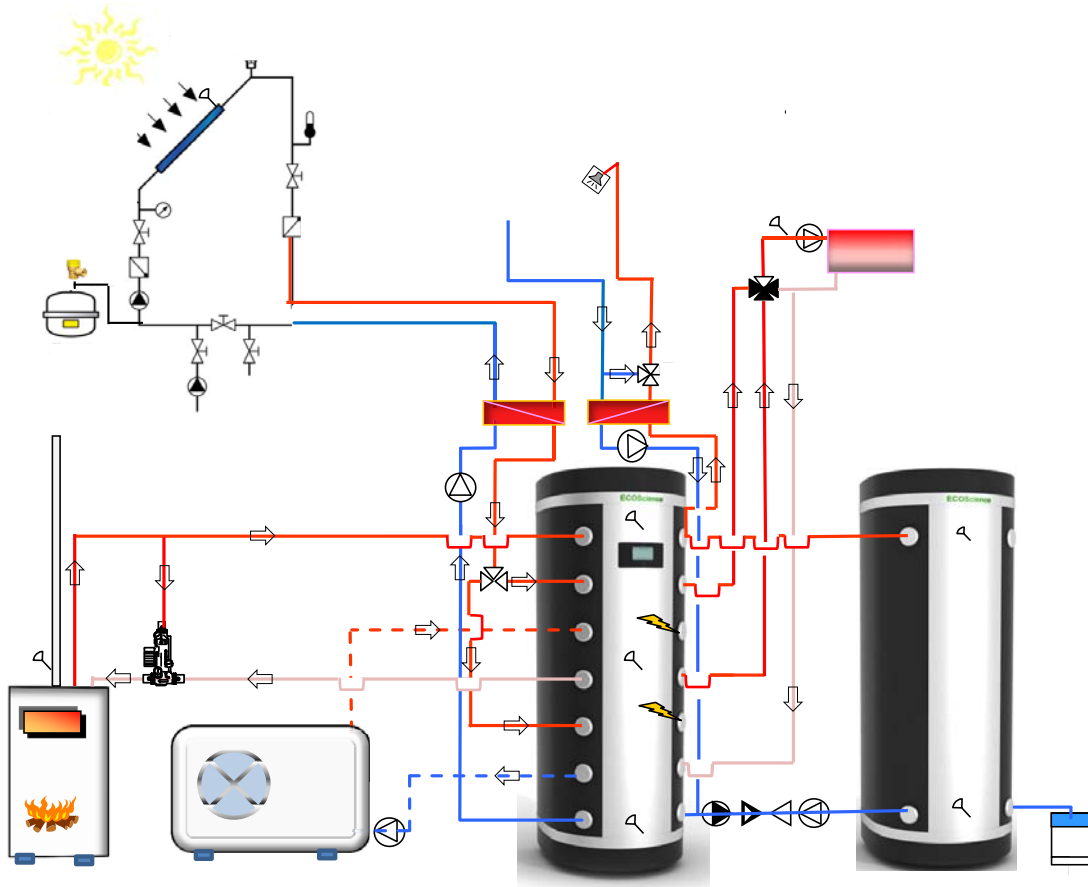

Figure 3. Schematic view of the system integration (with front connected piping)

#### 3.1 GENERAL

The ECOScience Energy Centre is designed for domestic use and provides a complete solution for heating and hot water.

The ECOScience Energy Centre enables you to harness and store energy efficiently from many sources (e.g. solar energy, heat pump (air or ground-sourced)/CHP/fuel cell or solid fuel/oil/gas/district heating). The energy is then used to produce hot tap water and heat for radiators or underfloor heating. It can also be used to heat a swimming pool.

The ECOScience Energy Centre comprises a system tank, an energy central unit and a control system as standard. You can also choose certain add-on modules e.g. solar heating system, solid fuel (water-jacketed pellet/wood stove, pellet/wood boiler), buffer tank, heat pump and pool heating.

### 3.1.1 System tank

The system tank is a water-filled tank that can be connected to external energy sources. The heat energy for producing hot water can therefore come from several different energy sources depending on the add-on modules you have chosen. The standard system tank also has 2 built in electric heaters (4.5 kW each) that can provide hot tap water and heating separately (top heater and bottom heater). You can choose how much power (1.5 kW, 3 kW or 4.5 kW) you want the electric heaters to contribute using the control system.

There are three temperature sensors in the system tank, positioned at the top, in the middle and at the bottom of the tank. The water at the top of the tank is used for hot tap water, the water in the middle supplies the radiators and the water at the bottom is used for underfloor heating or air ventilation heating and for pool heating.

### 3.1.2 Energy central unit

The energy central unit, which can be integrated into the top of the system tank, free-standing or wall-mounted, comprises a tap water circuit, a solar load circuit and a heat circuit.

The energy central unit features a safety valve that opens if the pressure in the system exceeds 1.5 bar.

#### 3.1.2.1 Tap water circuit

The tap water circuit manages the distribution of hot tap water for the house's existing pipe system and is equipped with a heat exchanger. This allows tap water to be heated quickly and means that no water is left standing in the system, thus eliminating any risk of Legionella growth.

The tap water circuit features a mixing valve to prevent scalding.

#### 3.1.2.2 Solar loading circuit

The solar load circuit features a heat exchanger, a circulation pump and a bivalent valve to distribute the hot water to the right level in the system tank.

### 3.1.2.3 Heat circuit

The heat circuit manages the distribution of hot water to the radiators or underfloor heating. If you only have radiators or underfloor heating, the control system coordinates the distribution of heat using a shunt valve and a circulation pump, in conjunction with indoor and outdoor sensors. The shunt valve mixes the hot supply water from the system tank with the colder water from the return pipe so that the right temperature is achieved for the water that feeds the radiators or underfloor heating. The shunt valve is controlled using sensors that measure the outdoor temperature, the indoor temperature and the supply pipe temperature.

If you have both radiators and underfloor heating, the control system can only control the radiators. An external control unit is therefore required for controlling underfloor heating. For further information contact your Service Representative.

### 3.1.3 Control system

The control system ensures that at any given time, the most efficient energy source is prioritised in order to produce the energy needed to heat the water in the system tank.

The control system is operated using a colour touchscreen located on the front of the system tank.

General settings are already programmed in the control system when it is delivered (see 'APPENDIX 4 - DEFAULT SETTINGS'), although each installation will require customer-specific settings to optimise the system. The installation engineer will do this during initial setup.

## 4 ASSEMBLY AND INSTALLATION

---

### 4.1 BEFORE USE

---

Check that the packaging is intact and the product is not damaged before using it. Check that none of the parts specified on the delivery note are missing.

#### 4.1.1 Safe disposal of packaging material

Sort the packaging by material according to local regulations.



#### **PLEASE NOTE: PACKAGING CAN BE RECYCLED!**

In the development of ECOScience products and the choice of materials used, much attention has been paid to environmental considerations. Packaging can be sorted into waste types for disposal and recycled. ECOScience packaging material is therefore fully recyclable.

## 4.2 GENERAL

### PLEASE NOTE: EQUIPMENT!



ECOScience recommends the use of vacuum bleeding and top-up devices (Flamco ENA or equivalent for example) when setting up the product and system. This will ensure that the system water is correct, creating the right conditions for optimum energy exchange.  
If bleeding and top-up equipment is not used, ECOScience shall not be liable under warranty.

### PLEASE NOTE: INSTALLATION!



For flow chart see 'APPENDIX 2 - FLOW CHART'.

### PLEASE NOTE: INSTALLATION!



Installation must be carried out in accordance with the national standards and laws for heating and hot water installations.

### DANGER: RISK OF ELECTRIC SHOCK!



Always switch off the power before starting any work on the energy centre. Electrical installations must always be performed by a qualified electrician.

### CAUTION: RISK OF MALFUNCTION!



Air bleeds from the system during initial setup.

## 4.3 ASSEMBLING THE SUPPORT BASE AND SYSTEM TANK

### 4.3.1 Instructions

1. Ensure that the space intended to house the product is large enough and that the floor is capable of bearing its weight. A clear height of approximately 300 mm above the system tank is recommended in order to facilitate the installation and adjustments. For dimensions see '10 TECHNICAL DATA' on page 51.



#### PLEASE NOTE: SPACE FOR INSTALLATION!

There must be a floor drain where the system tank and buffer tank are housed.

2. Remove the product from the packaging and carefully check that no damage has occurred during transport/handling.
3. Lift out the support base and check that all 6 adjustable feet (1 of which is spare) have been included.
4. Attach the feet to the support base.
5. Place the support base where the tank is to be installed.
6. Check that the support base sits flat using a spirit level as shown in according to 'Figure 4. Spirit level check'.

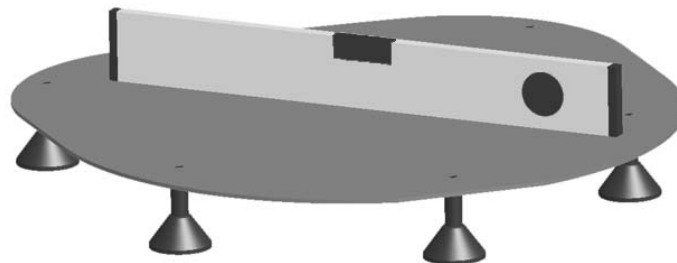

Figure 4. Spirit level check

7. Lift the product off the pallet and place it over the support base.
8. Check that the support base is positioned directly under the tank.
9. Check that the product is not obstructed by any surrounding equipment/structures.
10. Check again that the product sits flat using a spirit level, adjust the feet if necessary.



#### CAUTION: RISK OF INSTABILITY!

Check that the product sits flat after it has been filled to ensure its stability.

## 4.4 CONNECTING THE PIPES

### 4.4.1 Please note

- All existing or new systems must be flushed clean before any pipe fittings are connected permanently.
- The system tank must be connected to a closed expansion vessel. A manometer that indicates the system pressure must be mounted in the connection to the expansion vessel (see ' APPENDIX 2 - FLOW CHART'). (The manometer and expansion vessel are provided by the installation engineer.)
- The system pressure must not fall below 0.9 bar.
- ECOScience recommends stainless steel or PEX pipes. If these are not available, copper pipes should be used.



#### **CAUTION! CUTTING PIPES!**

In order to avoid any metal filings that may clog filters and connections and lead to corrosion in the system, pipes must only be cut with pipe cutters. Circular cutting saws or hacksaws must not be used.

- All connection fittings to the system are ¾”.

### 4.4.2 Instructions

1. Connect pipes as shown in the pipe connection diagrams.
2. Fit an existing or new circulation pump to the radiator circuit supply pipe (see ' APPENDIX 2 - FLOW CHART' and see ' APPENDIX 3 - WIRING DIAGRAM AND TEMPERATURE SENSORS').
3. Connect a hose between the safety valve and floor drain ("4.4.3 Pipe connections" No. 7).

4.4.3 Pipe connections

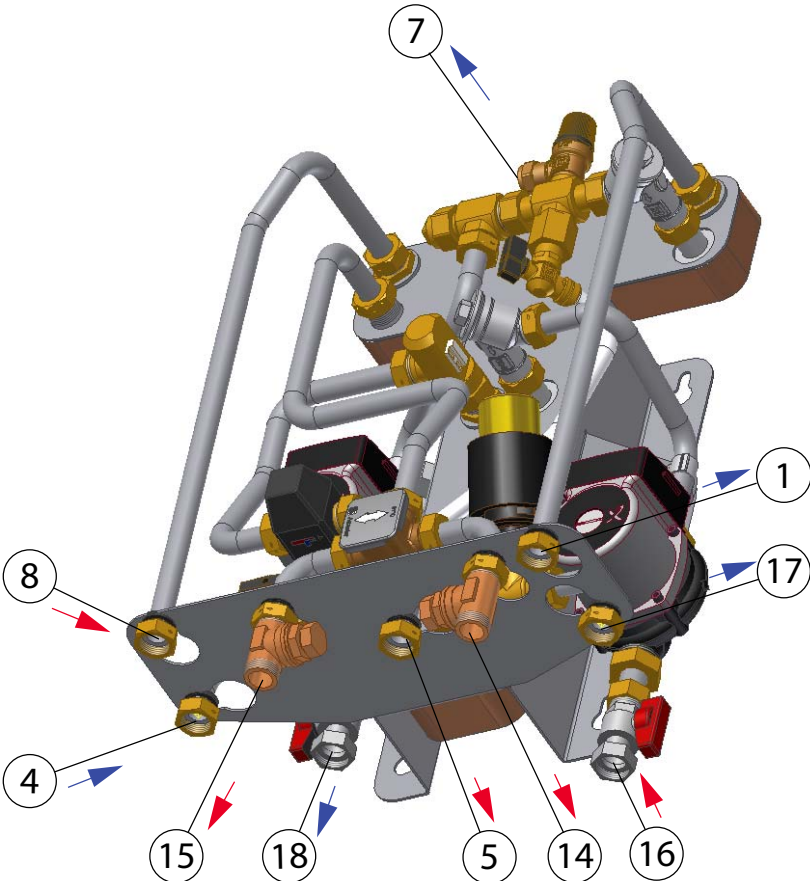

Figure 5. Energy Central Unit pipe connections

See 'Figure 8. List of pipe connections' on page 15. **Pipe connections for heat circuit:**

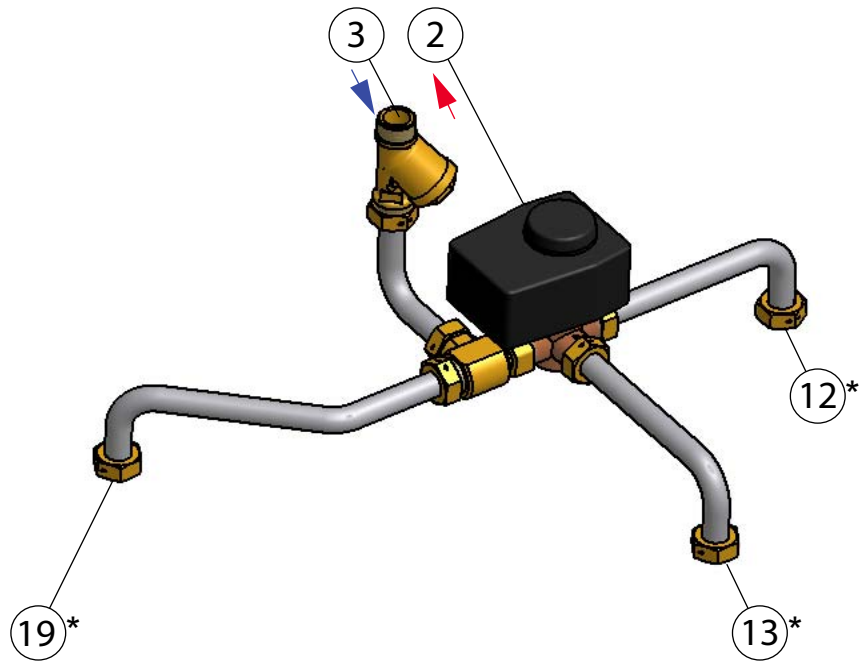

Figure 6. Pipe connections for top connected heat circuit

\* Connected when delivered.

See 'Figure 8. List of pipe connections' on page 15.

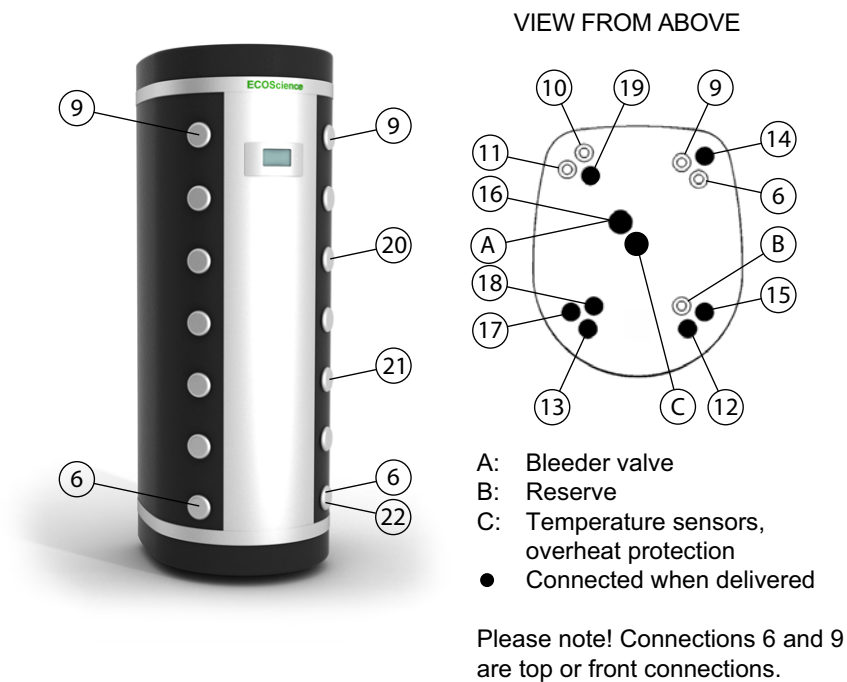

Figure 7. Pipe connections for top connected system tank

See 'Figure 8. List of pipe connections' on page 15.

No	Connection
1	Return solar circuit I (to collector)
2	Supply to radiator circuit
3	Return from radiator circuit
4	Incoming cold tap water
5	Outgoing hot tap water
6	Return to solid fuel without solar / Supply and return pump group buffer tank / Expansion vessel
7	Overflow pipe / Safety valve connection
8	Supply solar circuit I (from collector)
9 (i, wt)	Buffer tank loading and unloading
9 (wf)	Supply to tap water heat exchanger / Buffer tank Loading and unloading
10	Return to heat pump / Return from pool
11	Supply from heat pump low temp. / Return to solid fuel with solar / Supply to pool
12	Supply to bivalent shunt high temp
13	Supply to bivalent shunt low temp
14	Supply > 61°C solar circuit II (from solar heat exchanger)
15	Supply < 61°C solar circuit II (from solar heat exchanger)
16	Supply from solid fuel / Supply to tap water heat exchanger
17	Return from tap water heat exchanger
18	Return solar circuit II (to solar heat exchanger)
19	Return from bivalent shunt
20	Top electric heater
21	Bottom electric heater
22	Drain connection
23 (wf)	Supply from heat pump high temp. / Return to solid fuel with solar

Figure 8. List of pipe connections

*PLEASE NOTE: In order to facilitate installation, the connections at equal level on the system tank are optional. This means that pipe connections 16 and 9, for example, may be switched.*

*Supply = from energy source, hot water*

*Return = to energy source, cold water*

## 4.5 ASSEMBLY OF TEMPERATURE SENSORS AND OVERHEAT PROTECTION

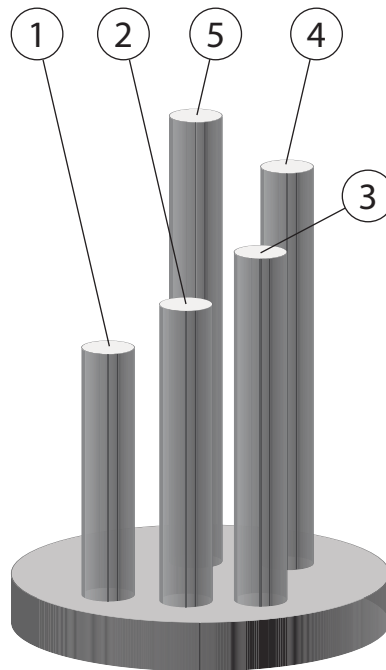

Figure 9. Tubes for temperature sensors and overheat protection see 'Figure 7. Pipe connections for top connected system tank' on page 14 No. C

1. Tube for the temperature sensor at the top of the system tank.
2. Tube for the overheat protection for the top electric heater in the system tank.
3. Tube for the temperature sensor in the middle of the system tank.
4. Tube for the overheat protection for the bottom electric heater in the system tank.
5. Tube for the temperature sensor at the bottom of the system tank.

### 4.5.1 Instructions

1. When replacing a temperature sensor or an overheat protection a few drops of oil should be poured into the tube before the installing of the temperature sensor or the overheat protection.

## 4.6 ELECTRICAL INSTALLATION

### 4.6.1 Please note

- All installations and reconnections in the connection box must be carried out by a qualified electrician.
- All wiring must be implemented in accordance with the applicable rules.
- The equipment must be permanently connected to the correct safety devices.
- High voltage power lines and low voltage cables must always be kept separate to prevent interference problems (also outside the product).
- The installation engineer is responsible for incoming switches.

### 4.6.2 Instructions

1. Connect the incoming three-phase cable to an approved safety switch.

**PLEASE NOTE: WIRING DIAGRAM!**

For wiring diagram see 'APPENDIX 3 - WIRING DIAGRAM AND TEMPERATURE SENSORS' on page 53.

**DANGER: RISK OF ELECTRIC SHOCK!**

Check that the switch is disconnected during wiring (i.e. no current is running through the system).

**PLEASE NOTE: CONNECTION INFORMATION!**

For connection information see '10.3 TECHNICAL DATA, CONTROL SYSTEM' on page 52.

**PLEASE NOTE: FOR SEPARATE CIRCUITS!**

If separate circuits are used for heating (via external heat exchangers), the cable of the existing circulation pump must be connected in parallel to the secondary pump via an IP-rated box.

## 4.7 FILLING THE SYSTEM WITH WATER



### CAUTION: RISK OF MALFUNCTION!

The side system containing glycol or another chemical mixture must be connected via the external heat exchanger.



### CAUTION: RISK OF MALFUNCTION!

If additional water is needed, the air bleeding process must be performed again.

### 4.7.1 Please note

- All side systems must be flushed clean and be free of any contamination. (Please note! Side systems must be flushed before being connected to the system tank. If this has not been done, these connections must be removed.)
- The pH value of the water used in the system should be between 7 and 8.5, the ideal value being 8.



### PLEASE NOTE: WATER QUALITY!

ECOScience recommends that a water sample be taken to ensure the quality of the water. The recommended pH value is between 7 and 8.5, 8 being the ideal value.

### 4.7.2 Instructions

1. Always check the initial pressure in the expansion vessel using an air pressure gauge before the system is filled.



### CAUTION!

If the pressure in the expansion vessel is too low, it must not be filled with regular air. Follow the manufacturer's instructions.

Height (m) (between expansion vessel and uppermost point of system)	Initial pressure (bar) in expansion vessel (before filling)	System pressure (bar)
0-7	0.9	1.1
8	1.0	1.2
9	1.1	1.3
10	1.2	1.3
11	1.3	1.3

- To ensure tap water is produced as intended, the system pressure must never fall below 0.9 bar.

**PLEASE NOTE: SYSTEM PRESSURE!**

The system pressure must never fall below 0.9 bar.

2. Check that the shut-off valves are open ("4.7.3 Connections and shut-off valves" (No. 1 and 3)).

**PLEASE NOTE: EQUIPMENT!**

ECOScience recommends the use of vacuum bleeding and top-up equipment (Flamco ENA or equivalent for example) when the product and system are being filled.

This will ensure that the system water is correct, creating the right conditions for optimum energy exchange.

If bleeding and top-up equipment is not used, ECOScience shall not be liable under warranty.

3. Make sure that the valve for bleeding air out of the system is open.
4. Connect the tap water via the tap water connection (No. 4) and fill with water until water comes out of the bleeding valve.
5. Close the bleeding valve and continue to fill with water until the desired system pressure is reached (min: 0.9 bar, max: 1.3 bar).
6. Check there are no leaks.
7. Close the shut-off valves (Nos. 1 and 3).
8. Remove hose (No. 2).

The system is now ready for commissioning (see '5 COMMISSIONING')

4.7.3 Connections and shut-off valves

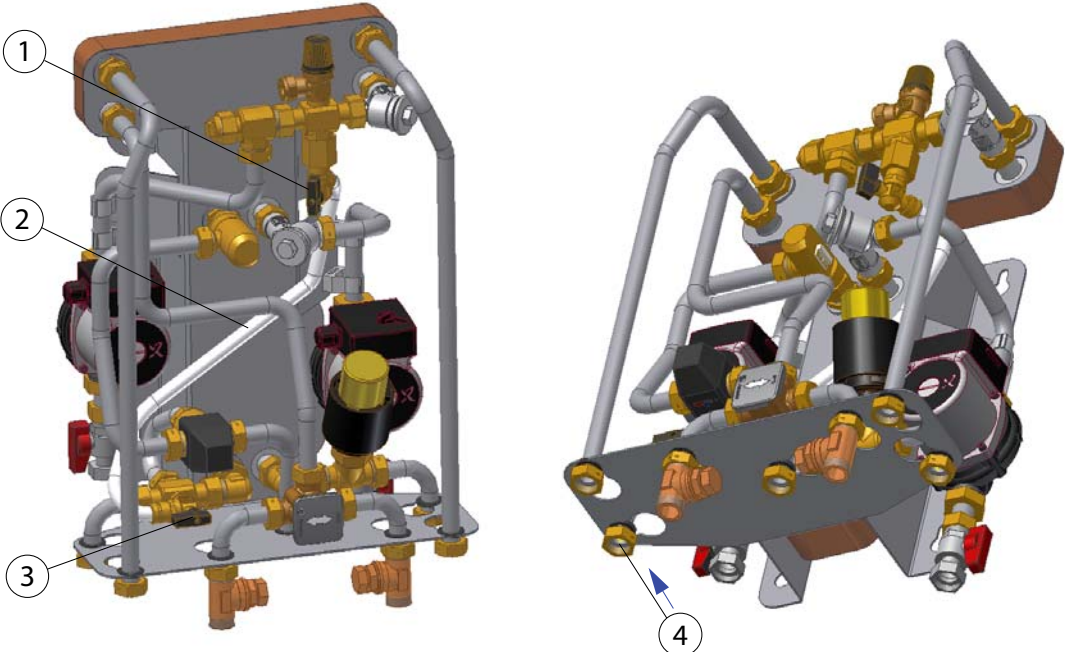

Figure 10. Filling the water system

- 1. Shut-off valve
- 2. Hose
- 3. Shut-off valve
- 4. Tap water connection

## 4.8 EMPTYING THE SYSTEM TANK

### 4.8.1 Instructions

**DANGER: RISK OF ELECTRIC SHOCK!**

Ensure no current is running through the system by turning the main switch to OFF before emptying the system tank.

**PLEASE NOTE: EMPTYING!**

A hose connection is supplied for emptying the system tank.

- Check that no current is running through the system.
- Remove the protection cover ( , No. 22). see 'Figure 7. Pipe connections for top connected system tank' on page 14
- Open the drain valve by screwing the stopper off.
- Connect a hose to the hose connection supplied and ensure that the other end of the hose is connected to a floor drain.

**WARNING: RISK OF SCALDING!**

Make sure than nothing comes into contact with the water being emptied from the system tank – risk of scalding.

- Fasten the hose connection to the drain valve. Note that the water starts to be drawn off as soon as the connection is fastened on.
- Open the valve for bleeding air out of the system at the top of the system tank , No. A) see 'Figure 7. Pipe connections for top connected system tank' on page 14

## 5 COMMISSIONING

---

Before operation, make sure you have read and understood section "2 SAFETY INSTRUCTIONS" onwards.



### RESPONSIBILITIES OF THE INSTALLATION ENGINEER!

The installation engineer is responsible for walking through the system with the end user.

### 5.1 PREPARATIONS BEFORE STARTING

---

Check that:

- The product is earthed.
- All parts are installed correctly and flushed clean.
- There are no leaks in the system.
- All sensors are mounted and connected properly. The installation engineer is responsible for ensuring that all sensors included with delivery are installed in accordance with the flow chart. Outdoor sensors must be positioned to be north-facing wherever possible. Indoor sensors must be positioned 1.60 m above the floor, in the centre of the house wherever possible and must not be exposed to direct sunlight or located near a heat source.

### 5.2 START-UP

---

1. Turn on the main switch so that the display window lights up.
2. If necessary: Adjust the settings in the control system to optimise the system.
3. Activate the heat-up sequence (see '6.3.3 Heat-up sequence').

### 5.3 NORMAL STOP

---

1. Ensure no current is running through the system by turning the main switch to OFF.

## 6 CONTROL SYSTEM



### PLEASE NOTE!

The ECOScience control system is pre-programmed in the factory so that the product can be started directly to provide heat and hot water. To restore these factory settings press 'Restore default values' in the Setup screen.

### 6.1 START SCREEN (BASIC MODEL)

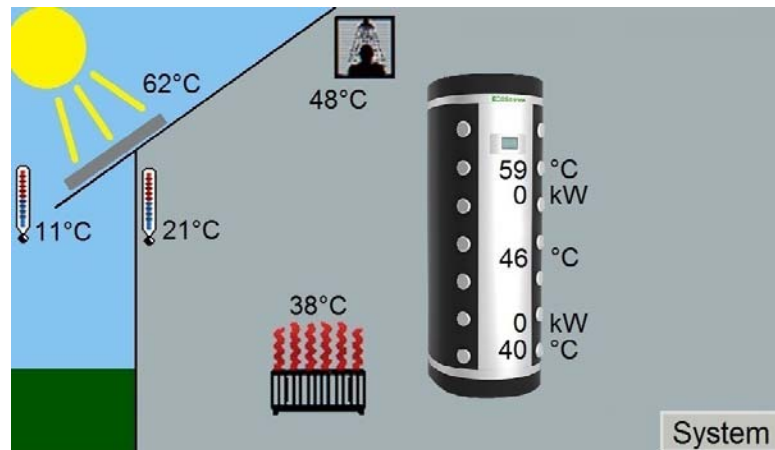

Figure 11. Basic start menu

- Press 'System' to continue.



### PLEASE NOTE: ADD-ON MODULES!

This is the start screen for the basic system. Other symbols will be displayed if add-on modules have been installed.

## 6.2 SYSTEM

All submenus for the system can be accessed from this menu. The submenus for general settings are displayed on the left. The submenus for setting the different modules are displayed on the right (the grey buttons indicate add-ons that have not been chosen).



**PLEASE NOTE: ADD-ON MODULES!**

Grey text indicates an add-on module, requiring a module key. To access extra add-ons please contact your Service Representative.

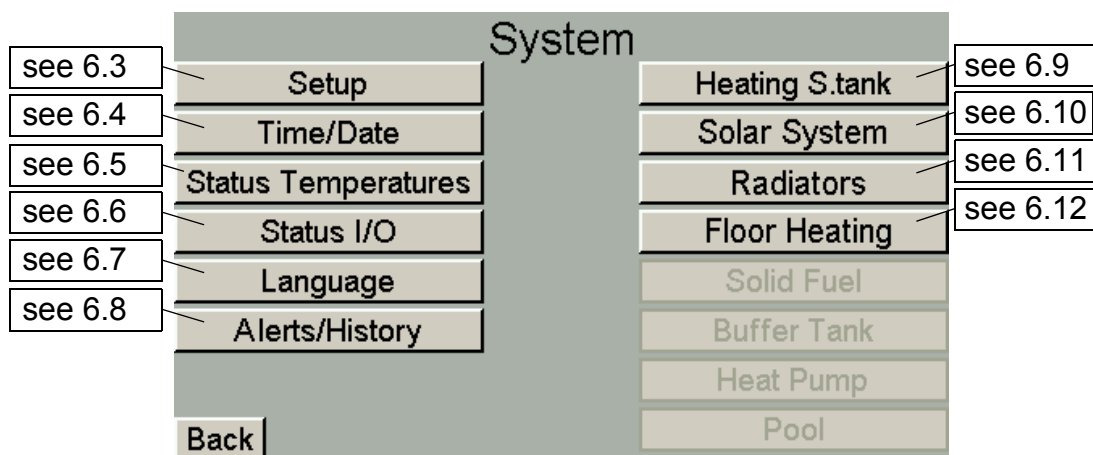

Figure 12. System menu

- Press the required button to continue.
- To return to the previous menu, press 'Back'.

### 6.3 SETUP

To access the Setup menu, you must first enter a password in the code menu.

The installation engineer also uses this menu to enter a code (known as a ‘module key’) if add-on modules are chosen.

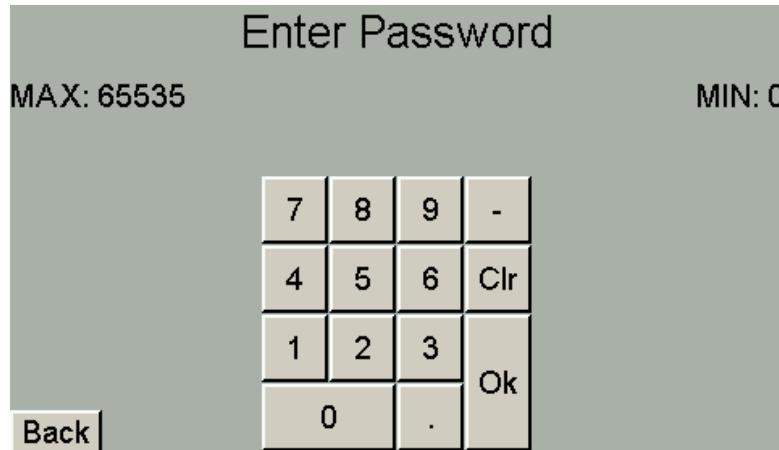

Figure 13. Setup code menu

- Press the grey password box and enter the code **55**. Then press OK to continue.

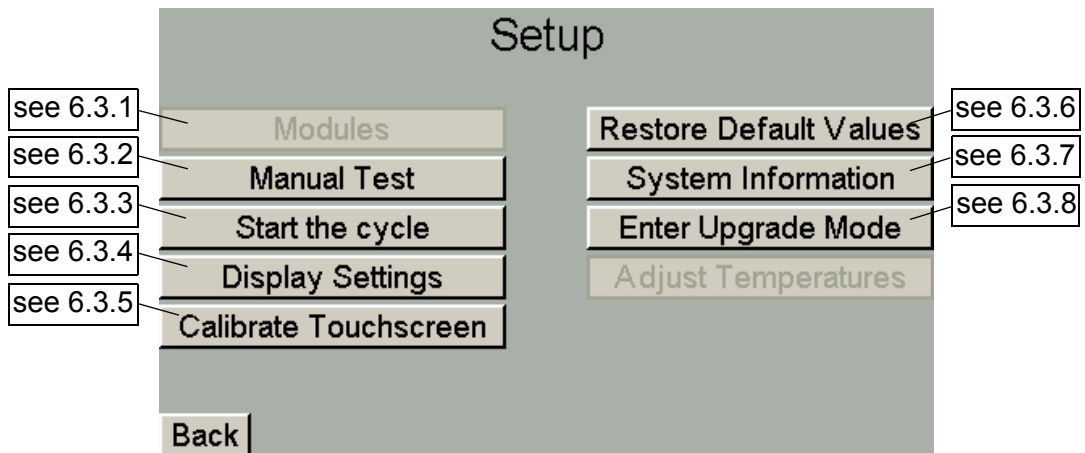

Figure 14. Setup menu

- Press the required button to continue.
- To return to the previous menu, press ‘Back’.

#### 6.3.1 Modules

This menu is used by the installation engineer if add-on modules have been chosen. A code is required to access this menu. Contact your installation engineer for more information.

### 6.3.2 Manual operation

Here you can switch between automatic and manual operation of the system.

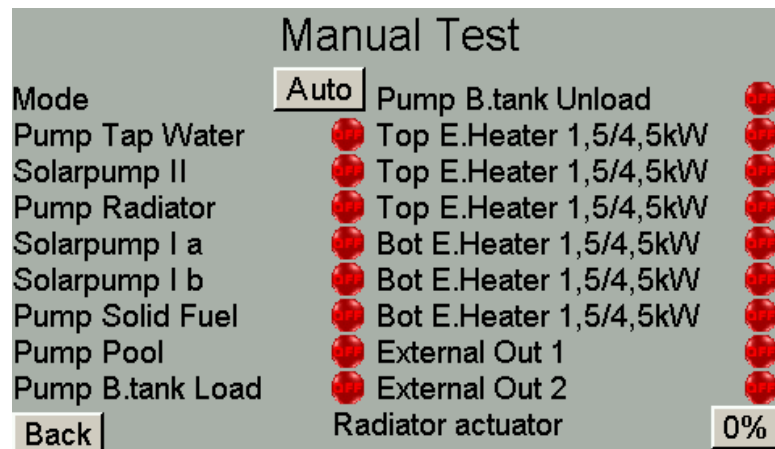

Figure 15. Menu 1 'Manual operation'

- To run the system manually, press 'Auto' so that the mode changes to 'Man'. (If the system is being operated manually, this is also indicated on the start screen by 'Manual operation' flashing on the screen.)
- To start or stop each function, press the lamp symbol (green=start, red=stop).
- External Out 1 and External Out 2 control any external heat sources that have been connected to the system (e.g. air-sourced heat pump, pellet stove etc.).
- To specify how far the actuator must open, i.e. the amount of water from the system tank that is to be distributed to the radiators/ underfloor heating, press the grey box marked 'Radiator actuator' and enter how far the actuator should open (enter value from 0 to 100%).
- To return to automatic operation, press 'Man' so that the mode changes to 'Auto'.
- To return to the previous menu, press 'Back'.

### 6.3.3 Heat-up sequence

When the system has been filled with water during installation and servicing, the water should be heated up to a certain temperature for a certain duration so as to ensure as little air in the system as possible.

During the heat-up sequence, air bleeds from the system via the bleeder valve.

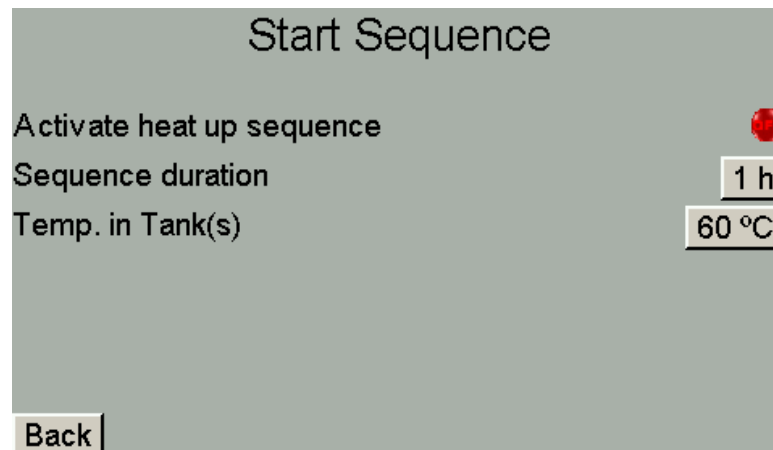

Figure 16. 'Start Sequence' menu

- Set the desired duration by entering the number of hours that the heat-up sequence should last (recommended duration: 2 hours).
- Specify the target temperature for the water by entering the desired temp. in tank/tanks (recommended temp.: 80°C).
- To activate the heat-up sequence, press the lamp symbol so that it turns green.
- To return to the previous menu, press 'Back'.

### 6.3.4 Display settings

Here you can program different settings for the display.

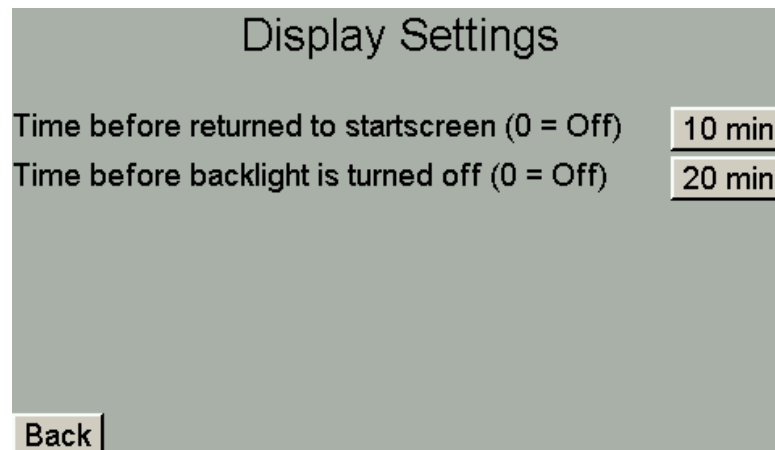

Figure 17. 'Display settings' menu

- Press the box for 'Time before returned to startscreen' and enter the desired value.
- Press the box for 'Time before backlight is turned off' and enter the desired value.

### 6.3.5 Calibrating the touchscreen

- Press the cross in the top left-hand corner.
- Press the cross in the bottom right-hand corner.
- The new settings are now stored.

### 6.3.6 Restore default values

Here you can restore the system to its default values.

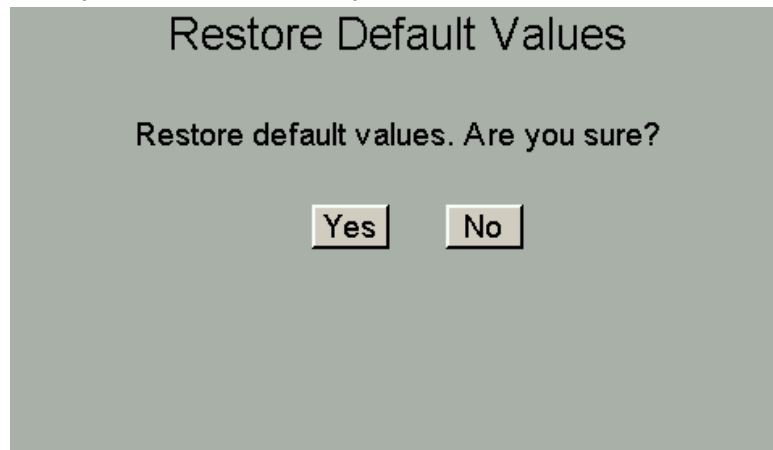



Figure 18. 'Restore Default Values' menu

- Press 'Yes' to restore default values.
- Press 'No' to retain your own settings.



**PLEASE NOTE: DEFAULT VALUES!**  
See 'APPENDIX 4 - DEFAULT SETTINGS' for more information.

### 6.3.7 System information

Information about the system is shown here.

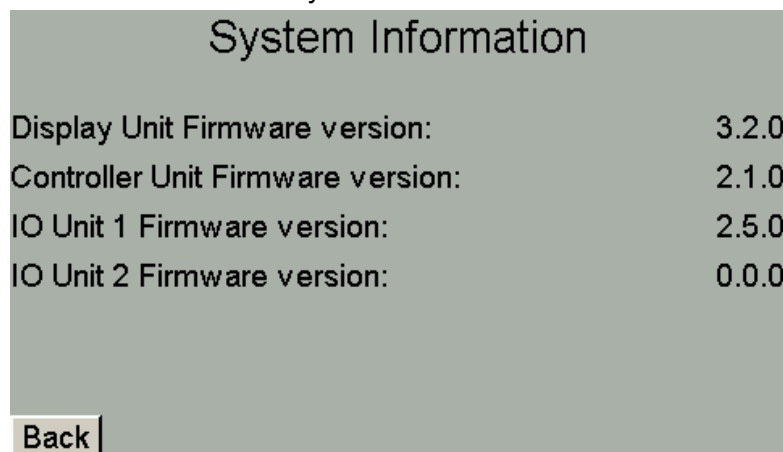

Figure 19. 'System Information' menu

- To return to the previous menu, press 'Back'.

### 6.3.8 Activating DFU mode

Activate DFU mode during upgrades.

### 6.3.9 Calibrating the temperature sensors

The temperature sensors can be calibrated here against the actual temperature. The installation engineer will measure the temperatures for checking purposes during installation. In the event of any deviations, the sensor in question should be adjusted (i.e. calibrated).

Temperature Adjustments					
Sensor	Temp. (°C)	Adj step	-	+	...
1.S.tank top	39.5 °C	0	-	+	...
2.S.tank mid	N/A °C	0	-	+	...
3.S.tank bottom	N/A °C	0	-	+	...
4.Indoors	21.5 °C	0	-	+	...
5.Outdoors	N/A °C	0	-	+	...
6.Radiator out	N/A °C	0	-	+	...

Back Next

Figure 20. Menu 1 'Temperature adjustments control circuit board'

Temperature Adjustments					
Sensor	Temp. (°C)	Adj step	-	+	...
7.Radiator return	N/A	0	-	+	...
8.Tap water circuit	N/A	0	-	+	...
9.Solar circuit II	N/A	0	-	+	...
10.Solar I a	N/A	0	-	+	...
11.Solar I b	N/A	0	-	+	...
12.Chimney exhaust temp.	134.5	0	-	+	...

Back Next

Figure 21. Menu 2 'Temperature adjustments control circuit board'

Temperature Adjustments IO1					
Sensor	Temp. (°C)	Adj step	-	+	...
B.tank top	N/A	0	-	+	...
Temp 2	N/A	0	-	+	...
B.tank bottom	N/A	0	-	+	...
Pool	N/A	0	-	+	...
Solid fuel out	N/A	0	-	+	...
Solid fuel return	N/A	0	-	+	...

Back Next

Figure 22. Menu 1 'Temperature adjustments I/O circuit board'

Temperature Adjustments IO1						
Sensor	Temp. (°C)	Adj step				
Temp 7	N/A	0	-	+	...	
Temp 8	N/A	0	-	+	...	
Temp 9	N/A	0	-	+	...	
Temp 10	N/A	0	-	+	...	
Temp 11	N/A	0	-	+	...	
Temp 12	N/A	0	-	+	...	
<b>Back</b>						

Figure 23. Menu 2 'Temperature adjustments I/O circuit board'

- "To calibrate the sensor in question press '-' or '+' until the actual temperature is shown.
- "To go to the next menu, press 'Next'.
- "To return to the previous menu, press 'Back'.

## 6.4 DATE/TIME

The date and time are set here.

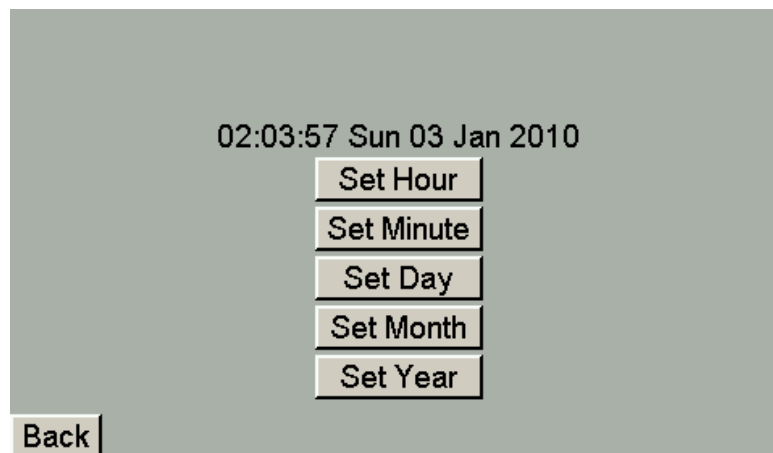

Figure 24. 'Date/Time' menu

- Press the required box and enter the correct date and time.
- To return to the previous menu, press 'Back'.

## 6.5 STATUS TEMP.

The current values indicated by the integrated temperature sensors are shown here.

Status Temp.			
1.S.tank top	39.5 °C	10.Solar I a	N/A °C
2.S.tank mid	N/A °C	11.Solar I b	N/A °C
3.S.tank bottom	N/A °C	12.Chimney	
4.Indoors	21.5 °C	exhaust temp.	134.5 °C
5.Outdoors	N/A °C		
6.Radiator supply	N/A °C		
7.Radiator return	N/A °C		
8.Tap water circuit	N/A °C		
9.Solar circuit II	N/A °C		

Back Next

Figure 25. 'Status Temp.' menu

- Press 'Next' to see more values.
- To return to the previous menu, press 'Back'.
- N/A may indicate the sensor is broken or is not connected, i.e. the module is missing.

### 6.6 STATUS I/O

The status of the system’s various units is shown here. The light symbols indicate which units are active at the moment (green = active) (“6.6.1 Explanation of ‘Status I/O’ menu”).

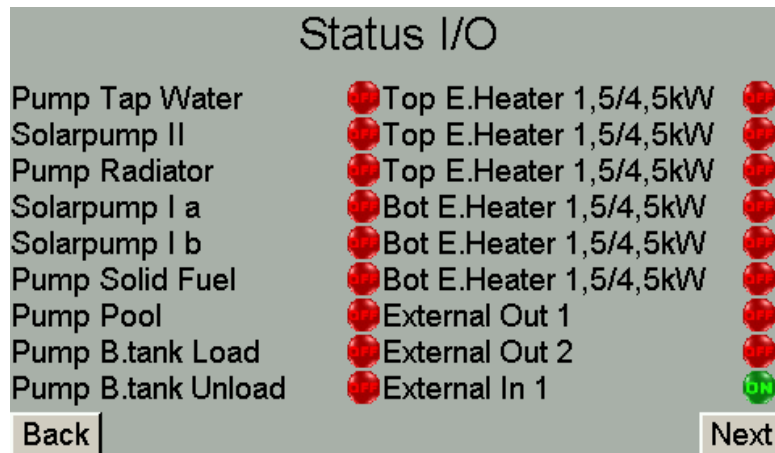

Figure 26. Menu 1 ‘Status I/O’

- Press ‘Next’ to see more units.
- To return to the previous menu, press ‘Back’.

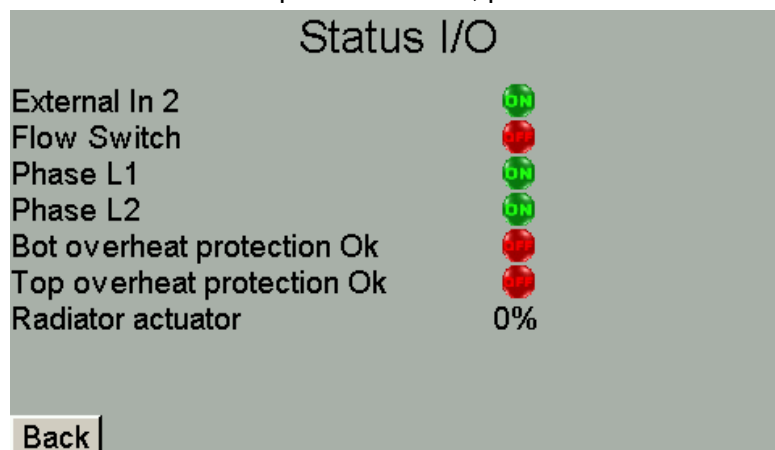

Figure 27. Menu 2 ‘Status I/O’

- To return to the previous menu, press ‘Back’.

**6.6.1 Explanation of ‘Status I/O’ menu**

	<b>Lamp indicator Green ON</b>	<b>Lamp indicator Red OFF</b>
<b>Pump Tap Water - (tap water circuit)</b>	The circulation pump between the system tank and the heat exchanger for hot tap water (so-called secondary side) is operating.	The circulation pump is not operating (for example when no hot water is being drawn).
<b>Solar pump II -</b>	The circulation pump between the system tank and the heat exchanger for the solar circuit (so-called secondary side) is operating.	The circulation pump is not operating (see ‘Installation and user manual, solar heating system’ for information)
<b>Pump Radiator - (heat circuit)</b>	The circulation pump between the system tank and the radiators/ underfloor heating (i.e. heating in the house) is operating.	The circulation pump is not operating (for example when no extra heating is needed in the house).
<b>Solar pump I a 1 - (single solar circuit)</b>	The circulation pump between the solar panels and the heat exchanger for the solar load circuit (so-called primary side) is operating.	The circulation pump is not operating (see ‘Installation and user manual, solar heating system’ for information)
<b>Solar pump I b 2 - (double solar circuit)</b>	The circulation pump between the solar panels and the heat exchanger for the solar load circuit (so-called primary side) is operating.	The circulation pump is not operating (see ‘Installation and user manual, solar heating system’ for information)
<b>Pump Solid Fuel -</b>	The circulation pump between the solid fuel source and the system tank is operating.	The circulation pump is not operating (see ‘Installation and user manual, solid fuel’ for information)
<b>Pump Pool -</b>	The circulation pump between the pool exchanger and the system tank is operating.	The circulation pump is not operating (see ‘Installation and user manual, pool’ for information)
<b>Pump B.tank Load -</b>	The circulation pump between the system tank and the buffer tank is operating.	The circulation pump is not operating (see ‘Installation and user manual, buffer tank’ for information)
<b>Pump B.tank Unload -</b>	The circulation pump between the buffer tank and the system tank is operating.	The circulation pump is not operating (see ‘Installation and user manual, buffer tank’ for information)
<b>Top Electric Heater 1.5/4.5kW</b>	The electric heater at the top of the system tank is on and producing 1.5 kW. Each lamp on means that the electric heater is producing 1.5 kW (2 lamps = 3 kW, 3 lamps = 4.5 kW).	The electric heater is not on.
<b>Bottom. Electric Heater 1.5/4.5kW</b>	The electric heater at the bottom of the system tank is on and producing 1.5 kW. Each lamp on means that the electric heater is producing 1.5 kW (2 lamps = 3 kW, 3 lamps = 4.5 kW).	The electric heater is not on.
<b>External Out 1 -</b>	External heat source has started.	External heat source has stopped.
<b>External Out 2 -</b>	External heat source has started.	External heat source has stopped.
<b>External In 1 -</b>	Option to connect external control unit.	External control unit is off.
<b>External In 2 -</b>	Option to connect external control unit.	External control unit is off.
<b>Flow Switch</b>	Tap water flows and the switch starts the circulation pump for tap water heat exchanger.	No tap water flows.

	Lamp indicator Green ON	Lamp indicator Red OFF
<b>Phase L1</b>	Incoming phase is OK, normal.	Phase missing (see '9.1 COMMON FAULTS AND SOLUTIONS')
<b>Phase L2</b>	Incoming phase is OK, normal.	Phase missing (see '9.1 COMMON FAULTS AND SOLUTIONS')
<b>Bottom overheat protection Ok</b>	overheat protection for the bottom electric heater in the system tank has not been triggered.	overheat protection for the bottom electric heater in the system tank has been triggered. (see '9.3.1 Resetting overheat protection for electric heaters')
<b>Top overheat protection Ok</b>	overheat protection for the top electric heater in the system tank has not been triggered.	overheat protection for the top electric heater in the system tank has been triggered. (see '9.3.1 Resetting overheat protection for electric heaters')
<b>Radiator Actuator</b>	Indicates how far the actuator is to open, determining the amount of water from the system tank that is to be distributed to the radiators/underfloor heating.	

## 6.7 LANGUAGE

The language to be used in the display is selected here.



Figure 28. 'Language' menu

- Press the required flag to change the language.
- To return to the previous menu, press 'Back'.

## 6.8 ALERTS/HISTORY

The various alerts that the system has generated but that have not yet been acknowledged are shown here, together with the date and time the alert was triggered. For more information see '9.3 ALERTS AND SOLUTIONS').

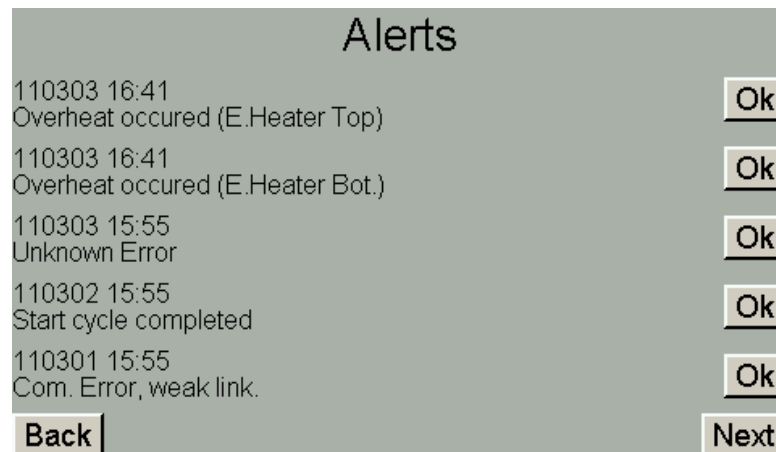

Figure 29. 'Alerts' menu

- To acknowledge an alert, press 'Ok'. Please note that some alert triggers may require mechanical resetting so as to be acknowledged, e.g. the overheat protection for the electric heater (see '9.3.1 Resetting overheat protection for electric heaters' on page 50).
- To see more alerts press 'Next'.
- To see the alert history press 'Next' again.

This menu shows the alerts previously generated by the system, together with the date and time they occurred.

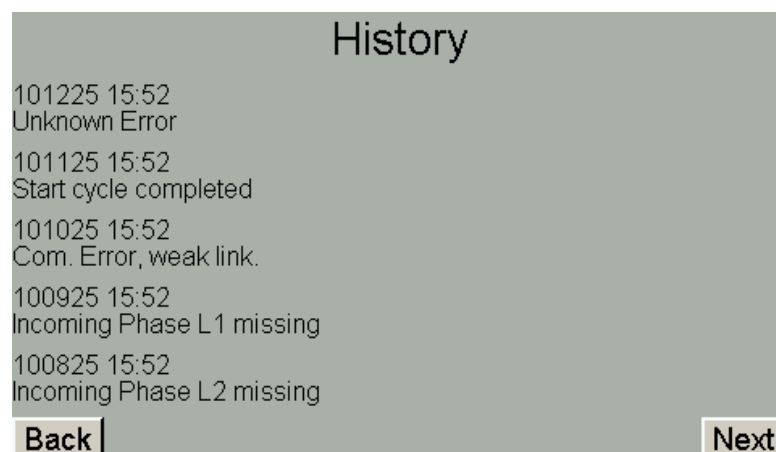

Figure 30. 'History' menu

- To see more alert history press 'Next'.
- To return to the previous menu, press 'Back'.

## 6.9 HEATING

This menu can be used to activate the heat sources from which energy is to be supplied to the system and to specify the temperatures at which these are to be activated. The temperatures at which the pool is to be heated are also set here, if you have chosen this add-on, together with the power that you want the electric heaters to supply to the system. You can also set the desired maximum temperature for the system tank.

The screenshot shows a control interface titled 'Heating, S.tank'. It has two columns: 'Start' and 'Stop'. Below these are rows for different heat sources, each with input boxes for start and stop temperatures, and a red indicator lamp. For 'E. Heater Top' and 'E. Heater Bottom', there are also 'Max' labels and dropdown menus for power (4.5 kW). At the bottom, there are boxes for 'Max temp. S.tank' (85 °C) and 'Max temp. Hyst.' (3 °C), and a 'Back' button.

	Start	Stop	
Solid Fuel	50 °C	75 °C	<input type="checkbox"/>
Heat Pump	40 °C	53 °C	<input type="checkbox"/>
E. Heater Top	60 °C	65 °C	Max <input type="checkbox"/> 4,5 kW
E. Heater Bottom	35 °C	45 °C	Max <input type="checkbox"/> 4,5 kW
Pool	45 °C	30 °C	<input type="checkbox"/>
Max temp. S.tank	85 °C	Max temp. Hyst.	<input type="checkbox"/> 3 °C

Figure 31. 'Heating, System tank' menu

- To set the start temperature for the heat source selected, press the required box under 'Start' and enter the temperature at which the heat source should start to supply heat to the system.
- To set the temperature at which the heat source should stop producing heat for the system tank, press the required box under 'Stop' and enter the desired temperature.
- When the start and stop temperatures have been selected, activate the heat source by pressing the red lamp symbol. This will turn green, indicating that the heat source has been activated and will produce heat for the system when the criteria (start and stop temperatures) are met.
- To set the power that the electric heaters need to produce for heating, press the box for the required electric heater and select 1.5 kW, 3 kW or 4.5 kW.
- A tolerance of several degrees can be set to prevent the system from switching off continuously when the temperature is around the maximum temperature programmed for the system tank.
- To return to the previous menu, press 'Back'.

## 6.10 SOLAR CIRCUIT

The ECOScience Energy Centre has been designed to accommodate a solar heating system. A solar loading circuit comprising a heat exchanger and bivalent valve that distributes water at the right level in the system tank is included in the basic model. See 'ECOScience Installation and user manual\_Solar heating system' for further details.

## 6.11 RADIATOR CIRCUIT

Here you can set the desired temperatures and times for the radiator circuit and the desired indoor temperature. You can also set the pump to stop when a certain outdoor temperature is reached. Stopping the pump means that in order to save energy and prevent unnecessary heating, the circulation pump to the radiators is turned off when the outdoor temperature reaches a certain level.

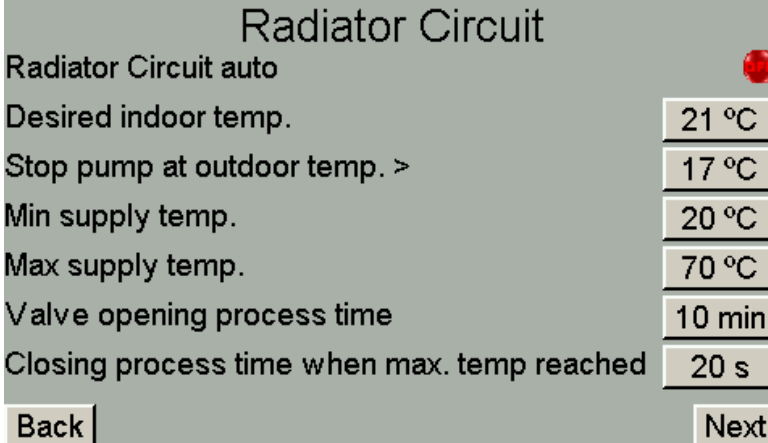

The screenshot shows a menu titled 'Radiator Circuit' with a red indicator light in the top right corner. The menu items and their corresponding values are as follows:

Radiator Circuit auto	
Desired indoor temp.	21 °C
Stop pump at outdoor temp. >	17 °C
Min supply temp.	20 °C
Max supply temp.	70 °C
Valve opening process time	10 min
Closing process time when max. temp reached	20 s
Back	Next

Figure 32. Menu 1 'Radiator Circuit'

- Press the required box and enter the desired value.
- To return to the previous menu, press 'Back'.
- To go to the next menu, press 'Next'.

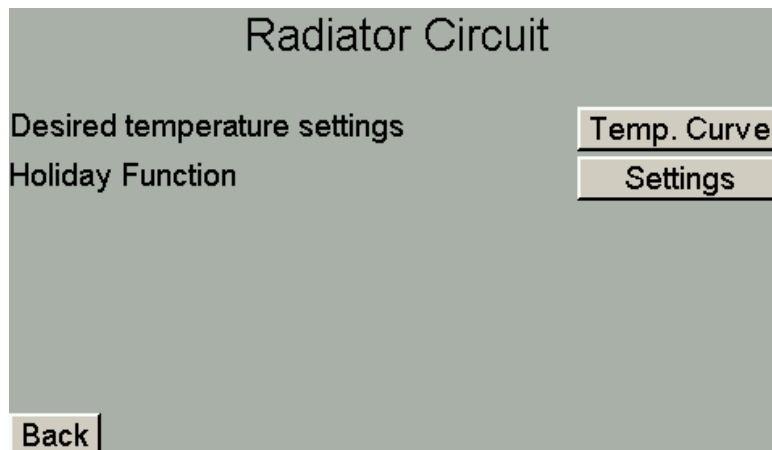

Figure 33. Menu 2 'Radiator Circuit'

- Press 'Temp. Curve' to access the menu for setting the temperature curve for the radiator circuit ("6.11.1 Radiator circuit temperature curve").
- Press 'Settings' to access the menu for temporarily reducing the temperature for the radiator circuit ("6.11.2 Scheduled temperature changes in radiator circuit").
- To return to the previous menu, press 'Back'.

### 6.11.1 Radiator circuit temperature curve

The temperature curve is shown here. This is based on a curve which is pre-programmed in the system.

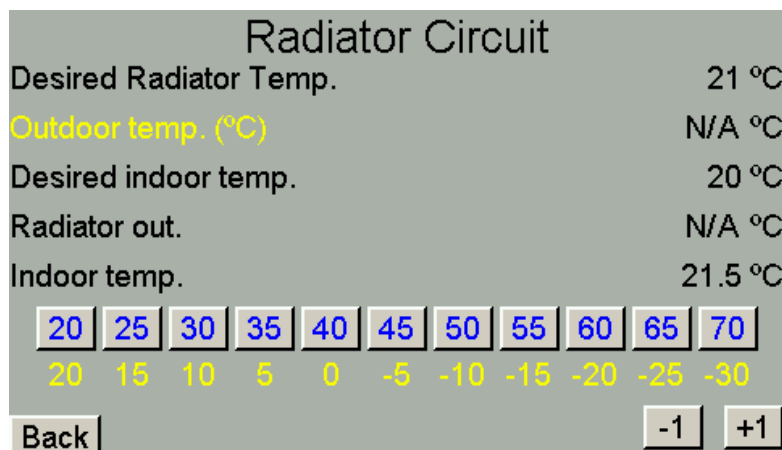

Figure 34. 'Radiator circuit temperature curve' menu

- For a parallel shift in the curve upwards or downwards press '+1' or '-1'.
- To set your own values for the curve press the grey boxes, enter the desired value and then press OK.
- To return to the previous menu, press 'Back'.

### 6.11.2 Scheduled temperature changes in radiator circuit

Temporary reductions in temperature in the building (-1°C to -3°C inclusive) can be programmed and activated in this menu for each day of the week.

		Mo	Tu	We	Th	Fr	Sa	Su	
OFF	00:00								-1 °C
	00:00								
OFF	00:00								-1 °C
	00:00								
OFF	00:00								-1 °C
	00:00								

Back Next

Figure 35. 'Scheduled temperature changes in radiator circuit' menu

- To set the time that the temperature reduction is to begin, press the time box (hr:min). Enter the desired time then click OK. Repeat this procedure for the time when the temperature reduction is to end and when the temperature is to return to its regular settings.
- To set the reduction in temperature (-1°C to -3°C inclusive) press the required temperature box and enter the desired value.
- To set the day of the week on which the temperature reduction is to start or end, press the box for the required day of the week. The box will then appear crossed.
- To activate the temperature reduction, press the lamp symbol, which then turns green.
- If a larger reduction in temperature is required or a temperature reduction for a longer period, press 'Next' to access the holiday reduction settings for radiators.
- To return to the previous menu, press 'Back'.
- To go to the next menu, press 'Next'.

### 6.11.3 Radiator circuit holiday settings

This menu can be used to program and activate holiday settings for radiators.

Radiator Circuit

Holiday Function 

Start date                      End date

YY MM DD HH MM              YY MM DD HH MM

10 01 01 00 00              10 01 01 00 00

Desired Temp. during holiday      17 °C

Back

Figure 36. 'Radiator circuit holiday settings' menu

- Enter the start date when the reduction in temperature is to start or the end date when the temperature is to return to its regular settings.
- Enter the desired temperature during holiday.
- To activate the holiday settings, press the lamp symbol, which then turns green.
- To return to the previous menu, press 'Back'.

## 6.12 FLOOR HEATING CIRCUIT

Here you can set the temperature and times for underfloor heating and the desired indoor temperature. You can also set the pump to stop when a certain outdoor temperature is reached. Stopping the pump means that the circulation pump for the floor heating is turned off when the outdoor temperature reaches a certain level in order to save energy and prevent unnecessary heating.

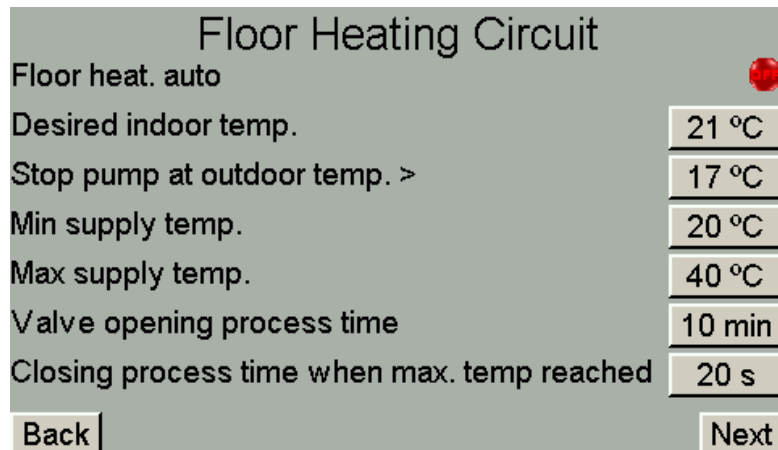

Figure 37. Menu 1 'Floor Heating Circuit'

- Press the required box and enter the desired value.
- To return to the previous menu, press 'Back'.
- To go to the next menu, press 'Next'.

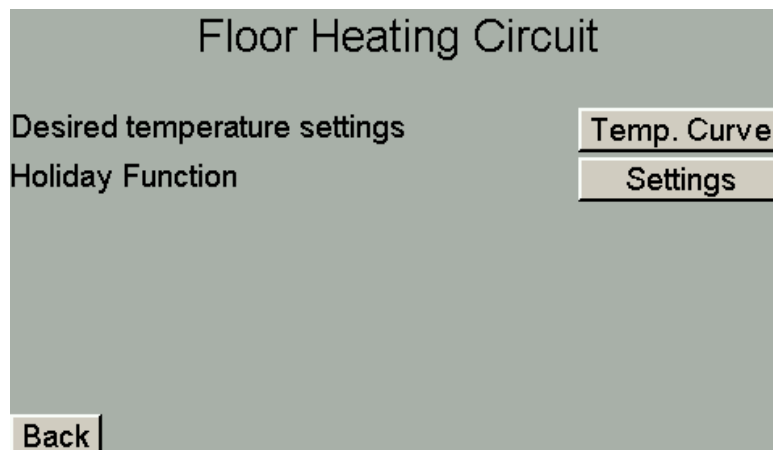

Figure 38. Menu 2 'Floor Heating Circuit'

- Press 'Temp. curve' to access the menu for setting the temperature curve for the floor heating circuit ("6.12.1 Floor heating circuit temperature curve").
- Press 'Settings' to access the menu for temporarily reducing the temperature for floor heating ("6.12.2 Scheduled temperature changes in floor heating circuit").

### 6.12.1 Floor heating circuit temperature curve

The temperature curve is shown here. This is based on a curve which is pre-programmed in the system.

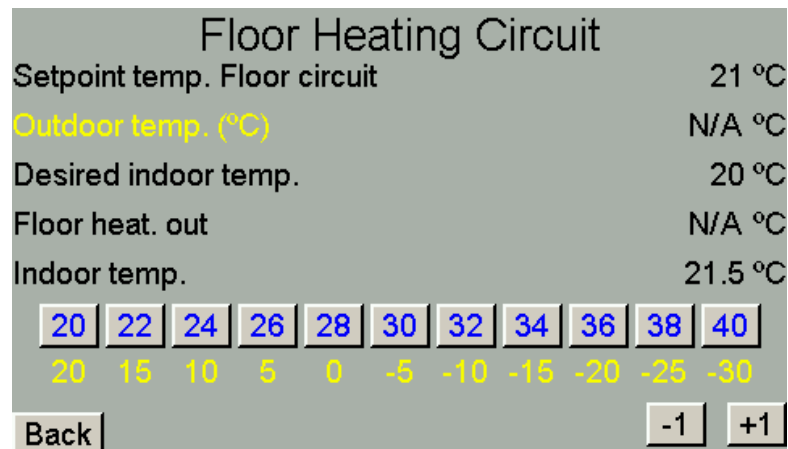

Figure 39. 'Floor heating circuit temperature curve' menu

- For a parallel shift in the curve upwards or downwards press '+1' or '-1'.
- To set your own values for the curve press the grey boxes, enter the desired value and then press OK.
- To return to the previous menu, press 'Back'.

### 6.12.2 Scheduled temperature changes in floor heating circuit

Temporary reductions in the temperature in the building (-1°C to -3°C inclusive) can be programmed and started/stopped in this menu for each day of the week.

		Mo	Tu	We	Th	Fr	Sa	Su	
OFF	00:00	<input type="checkbox"/>	<input type="checkbox"/>	<input type="checkbox"/>	<input type="checkbox"/>	<input type="checkbox"/>	<input type="checkbox"/>	<input type="checkbox"/>	-1 °C
	00:00	<input type="checkbox"/>	<input type="checkbox"/>	<input type="checkbox"/>	<input type="checkbox"/>	<input type="checkbox"/>	<input type="checkbox"/>	<input type="checkbox"/>	
OFF	00:00	<input type="checkbox"/>	<input type="checkbox"/>	<input type="checkbox"/>	<input type="checkbox"/>	<input type="checkbox"/>	<input type="checkbox"/>	<input type="checkbox"/>	-1 °C
	00:00	<input type="checkbox"/>	<input type="checkbox"/>	<input type="checkbox"/>	<input type="checkbox"/>	<input type="checkbox"/>	<input type="checkbox"/>	<input type="checkbox"/>	
OFF	00:00	<input type="checkbox"/>	<input type="checkbox"/>	<input type="checkbox"/>	<input type="checkbox"/>	<input type="checkbox"/>	<input type="checkbox"/>	<input type="checkbox"/>	-1 °C
	00:00	<input type="checkbox"/>	<input type="checkbox"/>	<input type="checkbox"/>	<input type="checkbox"/>	<input type="checkbox"/>	<input type="checkbox"/>	<input type="checkbox"/>	

Back Next

Figure 40. 'Scheduled temperature changes in floor heating circuit' menu

- To set the time that the temperature reduction is to begin, press the time box (hr:min). Enter the desired time then click OK. Repeat this procedure for the time that the temperature reduction is to end and the temperature is to return to its regular settings.
- To set the reduction in temperature (-1°C to -3°C inclusive) press the required temperature box and enter the desired value.
- To set the day of the week on which the temperature reduction is to start or end, press the box for the required day of the week. The box will then appear checked.
- To activate the temperature reduction, press the lamp symbol, which then turns green.
- If a larger reduction in temperature is required or a temperature reduction for a longer period, press 'Next' to access the holiday reduction settings for floor heating.
- To return to the previous menu, press 'Back'.
- To go to the next menu, press 'Next'.

### 6.12.3 Floor heating circuit holiday settings

This menu can be used to program and activate holiday settings for floor heating.

**Floor Heating Circuit**

Holiday Function 🔴

Start date                      End date

YY MM DD HH MM              YY MM DD HH MM

12 11 10 09 08              12 11 10 09 08

Desired Temp. during holiday      17 °C

Back

Figure 41. 'Floor Heating Circuit Holiday Settings' menu

- Enter the start date when the reduction in temperature is to start or the end date when the temperature is to return to its regular settings.
- Enter the desired temp. during holiday.
- To activate the holiday settings, press the lamp symbol, which then turns green.
- To return to the previous menu, press 'Back'.

### 6.13 SOLID FUEL

---

Only when the add-on module is chosen. See 'ECOScience Installation and user manual – solid fuel' for further details.

### 6.14 BUFFER TANK

---

Only when the add-on module is chosen. See 'ECOScience Installation and user manual - buffer tank'.

### 6.15 HEAT PUMP

---

Only when the add-on module is chosen. See 'ECOScience Installation and user manual - heat pump'.

### 6.16 POOL CONTROL

---

Only when the add-on module is chosen. See 'ECOScience Installation and user manual - pool'.

## 7 MAINTENANCE

---

Before maintenance and cleaning, make sure you have read and understood section "2 SAFETY INSTRUCTIONS".

### 7.1 MAINTENANCE AND FUNCTION CHECKS

---

#### 7.1.1 Regular maintenance to be carried out at least once a year

- Check the safety valve by turning it anti-clockwise until it jumps out. For the location of the safety valve see '4.4.3 Pipe connections' (No. 7).
- Check the pressure in the system by reading the manometer located in the connection to the expansion vessel.

**PLEASE NOTE: SYSTEM PRESSURE!**

The system pressure must never fall below 0.9 bar.

### 7.2 CLEANING

---

Wipe the product regularly using a rag, warm water and a mild detergent.

**CAUTION: RISK OF SURFACE DAMAGE!**

Never use corrosive agents or agents that could scratch the product!

## 8 SERVICING AND REPAIRS

---

Servicing and repairs must be carried out by the installation engineer or his/her representative. Before servicing and repairs, make sure you have read and understood section "2 SAFETY INSTRUCTIONS".

**DANGER: RISK OF ELECTRIC SHOCK!**

Turn the main switch to OFF before servicing!  
The control panel must only be opened by qualified professionals!

## 9 TROUBLESHOOTING

### 9.1 COMMON FAULTS AND SOLUTIONS

Description of problem	Possible cause	Solution
Noise from pump or radiators/floor heating.	Often caused by air in the system.	Bleed the air out of the system, including the pump.
Fault in flow switch.	This may be due to dirt in the flow switch or if the switch is broken.	Clean the flow switch.
Low pressure in the system tank. Manometer shows a pressure of <0.9 bar.	Possible leak or air has bled from the system with no topping up.	Contact Service Representative.
No heat coming out to the radiators/ floor heating.	Manual operation of shunt has been activated via the control system or actuator has been set to manual.	Check that the system is not set to manual operation ("6.3.2 Manual operation")
	Error in radiator circuit circulation pump.	Contact your Service Representative if the circulation pump has a fault.
	Can be caused by air in the system.	Bleed the air out of the system, including the pump.
Phase L1 lamp illuminated in I/O menu	Fault with incoming phase (L1).	Contact a qualified electrician.
Phase L2 lamp illuminated in I/O menu	Fault with incoming phase (L2).	Contact a qualified electrician.
Temperature value on screen shows N/A.	Sensor broken or not connected.	Check sensor or contact Service Representative.
The control system indicates hot water being drawn but this is not happening.	Dirt may have collected in the flow switch from incoming cold water (municipal or from own well).	Clean the flow switch.
Temp. value on screen shows -40°C.	Broken sensor or broken wire.	Contact Service Representative for change of temp. sensor.

## 9.2 TABLE FOR RESISTANCE TEMPERATURE SENSOR PT 100

You can check that the temperature sensors are functioning properly by using the table below and an instrument for measuring resistance.

Temp °C	Resistance ohm	DR/Dt ohm/°C
-20	92.160	0.393
-10	96.086	0.392
0	100.000	0.391
10	103.903	0.390
20	107.794	0.389
30	111.673	0.387
40	115.541	0.386
50	119.397	0.385
60	123.242	0.384
70	127.075	0.383
80	130.897	0.382
90	134.707	0.380
100	138.506	0.379

### 9.3 ALERTS AND SOLUTIONS

The control system has a monitoring function which triggers an alert if something unexpected occurs. The alert is indicated by a red warning triangle on the start screen. The triangle simply indicates that an alert has occurred. To obtain more information on why the system has generated an alert, go to the 'Alerts' menu ("6.8 ALERTS/HISTORY").

Alert message	Meaning and solution
Overheat occurred (Electric Heater Top/Bottom)	Overheat protection for the electric heater has been triggered (see '9.3.1 Resetting overheat protection for electric heaters' on page 50).
Communication Error	Error in communication between control circuit board and I/O circuit board. Check cable.
Start Seq. completed	This is not an alert but notification that the start sequence is complete (for more information see '6.3.3 Heat-up sequence' on page 27).
Incoming Phase L1/L2 missing	Fault with incoming phase, contact qualified electrician.
Heating circuit supply temp. not reached.	Set value not reached. Possibly due to air in the heating system. Check the heating circuit circulation pump.

#### 9.3.1 Resetting overheat protection for electric heaters

If the system has generated an alert indicating that the overheat protection has been triggered for the top or bottom electric heater, it must be reset. Please note that this protection should not normally be triggered. However, if the protection has been triggered, the procedure is as follows:

- Unscrew the protection plug on the cover of the connection box which is located on the top of the tank and labelled 'overheat protection'.
- Reset the overheat protection by pressing down the white button quite hard with a blunt object.
- Refasten the screw on the cover of the connection box.
- Acknowledge the alert in the 'Alerts' menu, see '6.8 ALERTS/HISTORY' on page 36.



**PLEASE NOTE: OVERHEAT PROTECTION!**

If the overheat protection for the electric heaters is activated often, ask your service representative to troubleshoot the problem.

## 10 TECHNICAL DATA

### 10.1 TECHNICAL DATA, SYSTEM TANK

Model	6300wt	6500wt	8500wt	8750wt
Volume (litres)	312	520	520	780
Dimensions (LxWxH mm)	770x650x1410	770x650x2070	780x800x1670	780x800x2270
Tilt height (mm)	1660	2270	1960	2510
Overall height (mm)	1410	2070	1670	2270
Recommended room height (mm)	1710	2370	1970	2570
Required door width (mm)	700	700	800	800
Weight (kg)	47*)	64,5*)	60,5*)	77*)
Weight per support foot (kg)	71	117	116	171

Figure 42. Technical data

\*) Without energy central 21 kg

- The temperature in the system tank can be adjusted, but max. 90°C.
- System pressure: min. 0.9 bar, max. 1.3 bar.

### 10.2 TECHNICAL DATA, ENERGY CENTRAL UNIT

- Opening pressure of safety valve is 1.5 bar.
- System pressure, on tank side, for tap water heat exchanger:  $\geq 0.9$  bar.
- System pressure, on cold water side, for tap water heat exchanger: PN16
- Cleaning filters are fitted in the return pipe of the radiator circuit, and on the supply pipe (secondary side) in front of heat exchangers for hot tap water and for solar circuit.

### 10.3 TECHNICAL DATA, CONTROL SYSTEM

<b>Version</b>	<b>ControlScience 300</b>
<b>Type</b>	PCB-based
<b>Display</b>	4.3" TFT touchscreen
<b>Enclosure rating</b>	IP65
<b>Type of enclosure</b>	Toughened PC
<b>Max. usage temp</b>	70°C.
<b>Dimensions (LxWxH mm)</b>	255x230x60
<b>Weight (kg)</b>	3.6
<b>Connection</b>	Permanent installation
<b>Voltage (V)</b>	400
<b>Fuse protection</b>	16 A
<b>Number of phases</b>	3

Figure 43. Control system CS300

## 11 APPENDICES

---

**APPENDIX 1 - EC DECLARATION OF CONFORMITY**

**APPENDIX 2 - FLOW CHART**

**APPENDIX 3 - WIRING DIAGRAM AND  
TEMPERATURE SENSORS**

**APPENDIX 4 - DEFAULT SETTINGS**

**APPENDIX 5 - LIST OF COMPONENTS**





**EG-försäkran om överensstämmelse**  
**EC-déclaration de conformité**  
**EC-declaration of conformity**  
**EG-Konformitätserklärung**

Fueltech Sweden AB  
P.O Box 507  
SE-372 25 RONNEBY

Tel: +46 (0)457-455 100  
Fax: +46 (0)457 455 125

försäkrar under eget ansvar att produkten  
confirme sous sa responsabilité exclusive que le produit  
declare under our sole responsibility that the product  
erklären in alleiniger Verantwortung, dass das Produkt

**Tank:** xxxxxx  
**Typ nummer:** xxxxxx  
**Produktfamilj:** xxxxxx

som omfattas av denna försäkran är i överensstämmelse med följande standarder,  
auquel cette déclaration se rapporte est en conformité avec les exigences des normes suivantes,  
to which this declaration relates is in conformity with requirements of the following directives,  
auf das sich diese Erklärung bezieht, konform ist mit den Anforderungen der Richtlinie,

<b>EU-direktiv:</b>	<b>2006/95/EC</b> <b>2004/108/EG</b> <b>2006/42/EG</b>	<b>Lågspänningsdirektivet</b> <b>EMC direktivet</b> <b>Maskindirektivet</b>
<b>Övrigt:</b>	<b>PED 97/23 artikel 3.3</b>	<b>Hållfasthetstest</b>
<b>Kvalitetssystem:</b>	<b>ISO 9001</b> <b>ISO 14001</b> <b>TS 16949</b>	

Överensstämmelsen är kontrollerad i enlighet med följande EN-standarder  
La conformité a été contrôlée conformément aux normes EN,  
The conformity was checked in accordance with the following EN-standards,  
Die Konformität wurde überprüft nach den EN-Normen,

<b>EN-14731:2006</b>	<b>EN-895</b>	<b>EN-9606-2:2005</b>
<b>EN-3834-2:2005</b>	<b>EN-15614-2:2005</b>	<b>EN-10042:2005</b>
<b>EN-1418</b>	<b>EN-10204:2005</b>	<b>EN-55014-1/-2</b>
<b>EN-61000-3</b>	<b>EN-60335-1</b>	<b>EN-50366:2002</b>

Ronneby xxxx-xx-xx

För sammanställning ansvarar  
Håkan Björnsson  
Quality Manager  
Fueltech Sweden AB



# Flow chart for heating and hot tap water

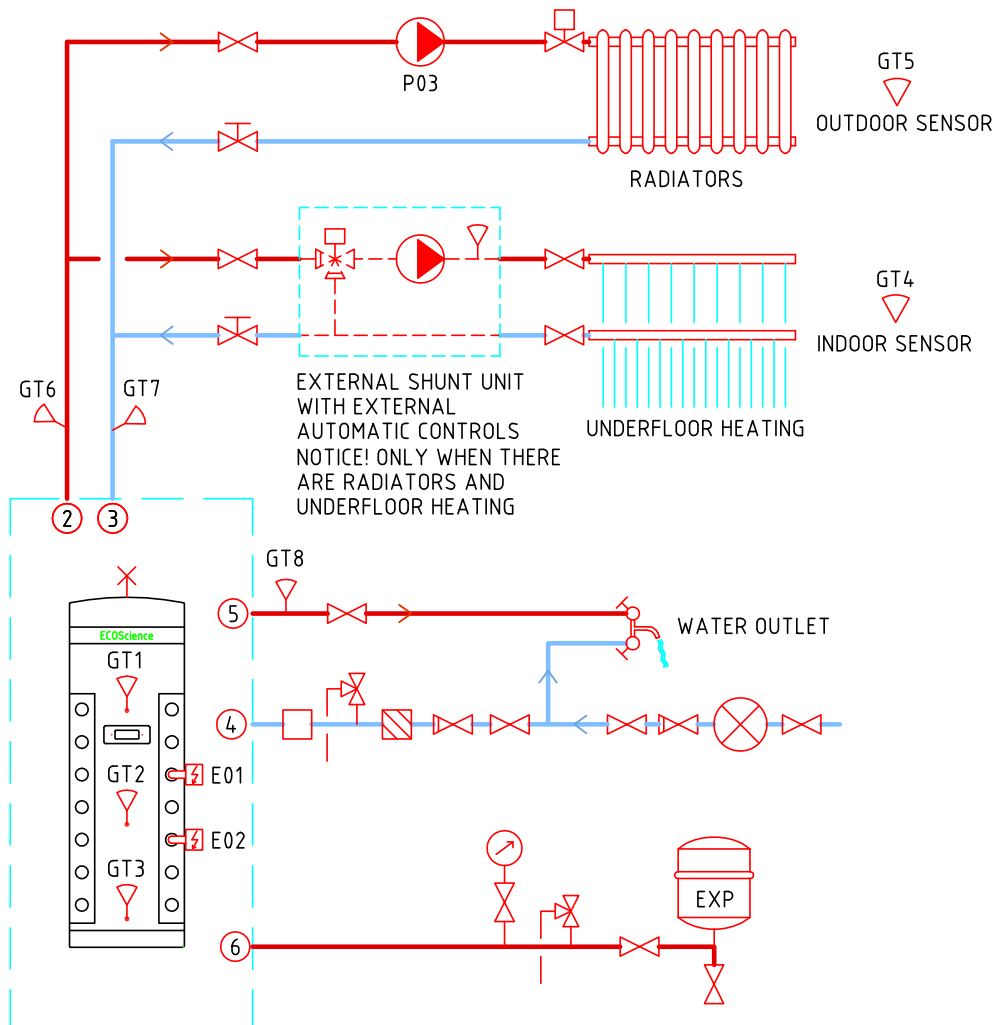

- |  |                               |  |                     |
|--|-------------------------------|--|---------------------|
|  | STOP VALVE                    |  | AIR BLEEDER         |
|  | CHECK VALVE                   |  | STRAINER, FILTER    |
|  | CONTROL VALVE (HAND OPERATED) |  | SENSOR, TEMPERATURE |
|  | CONTROL VALVE                 |  | PRESSURE GAUGE      |
|  | MIXING VALVE                  |  | THERMOMETER         |
|  | SAFETY VALVE                  |  | FLOW METER          |
|  | PUMP                          |  | FLOW SWITCH         |
|  | ELECTRIC HEATER               |  | EXPANSION VESSEL    |



# Wiring Diagram

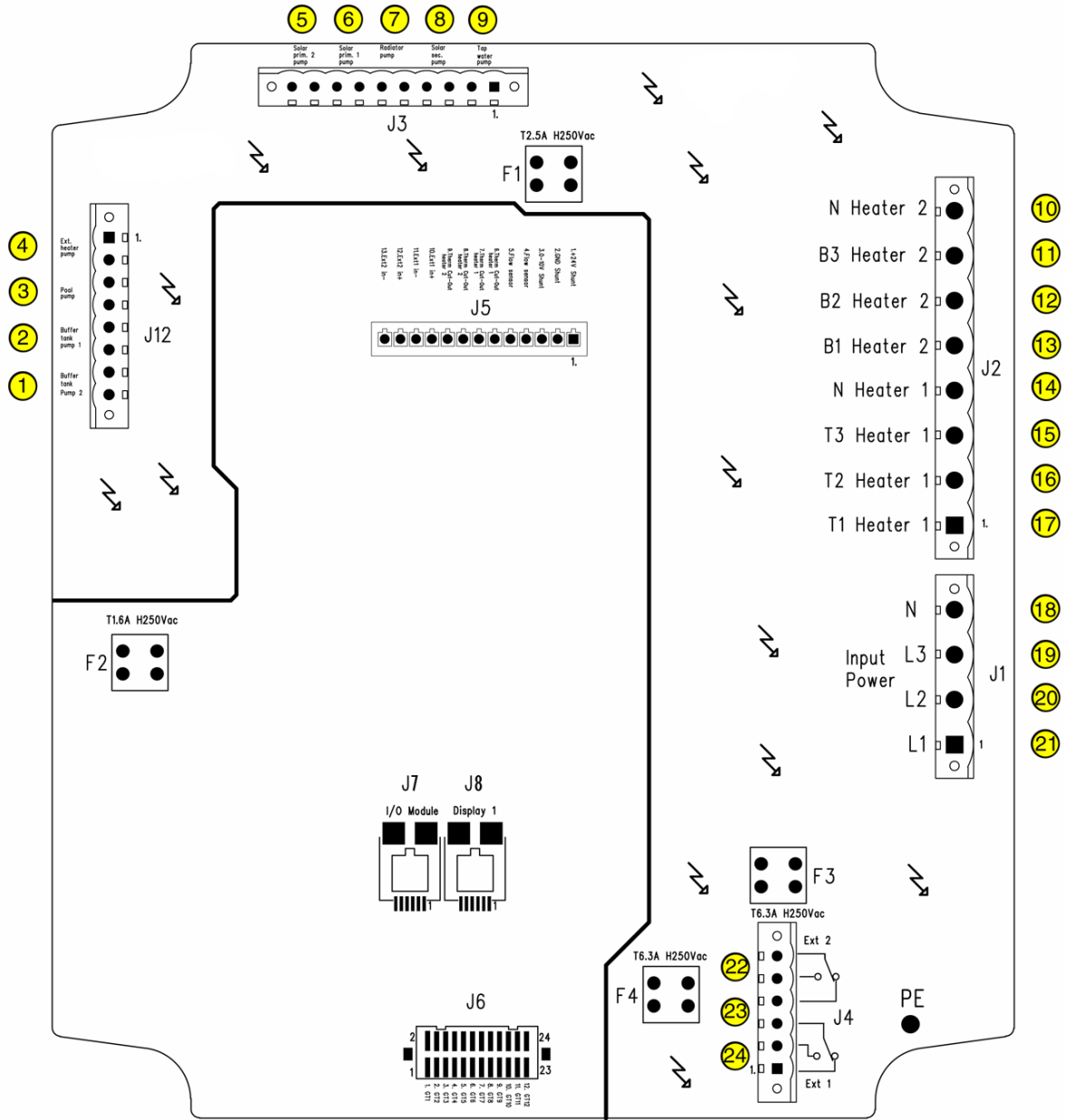



## Socket connections on circuit board

	Socket no:	External/Internal
J12 Circulation pumps	1	Buffer tank pump 2 (load buffer tank)
	2	Buffer tank pump 1 (unload buffer tank)
	3	Pool pump
	4	Pump for external heat source
J3 Circulation pumps	5	Solar pump primary 2
	6	Solar pump primary 1
	7	Radiator pump
	8	Solar pump (secondary side)
	9	Tap water pump (secondary side)
J2 Electric heaters	10	Electric heater 2 bottom N
	11	Electric heater 2 bottom B3
	12	Electric heater 2 bottom B2
	13	Electric heater 2 bottom B1
	14	Electric heater 1 top N
	15	Electric heater 1 top T3
	16	Electric heater 1 top T2
	17	Electric heater 1 top T1
J1 Incoming power supply	18	N
	19	L3
	20	L2
	21	L1
J4 External control	22	External control
	23	External control
	24	External control

Figure 44. Wiring diagram Control Science 300



## Temperature Sensors

### Control Circuit Board

Sensor	Cable Text	Function
"GT1"	"1"	System tank top
"GT2"	"2"	System tank mid
"GT3"	"3"	System tank bottom
"GT4"	"4"	Indoor temperature sensor
"GT5"	"5"	Outdoor temperature sensor
"GT6"	"6"	Radiators supply
"GT7"	"7"	Radiators return
"GT8"	"8"	Tap water
"GT9"	"9"	Secondary solar circuit
"GT10"	"10"	Primary I solar circuit
"GT11"	"11"	Primary II solar circuit
"GT12"	"12"	Exhaust solid fuel

### I/O Circuit Board

PCB-Text	Cable Text	Function
"GT13"	"1"	Buffer tank top
"GT14"	"2"	Spare
"GT15"	"3"	Buffer tank bottom
"GT16"	"4"	Pool
"GT17"	"5"	Solid fuel supply
"GT18"	"6"	Solid fuel return
"GT19"	"7"	Spare
"GT20"	"8"	Spare
"GT21"	"9"	Spare
"GT22"	"10"	Spare
"GT23"	"11"	Spare
"GT24"	"12"	Spare



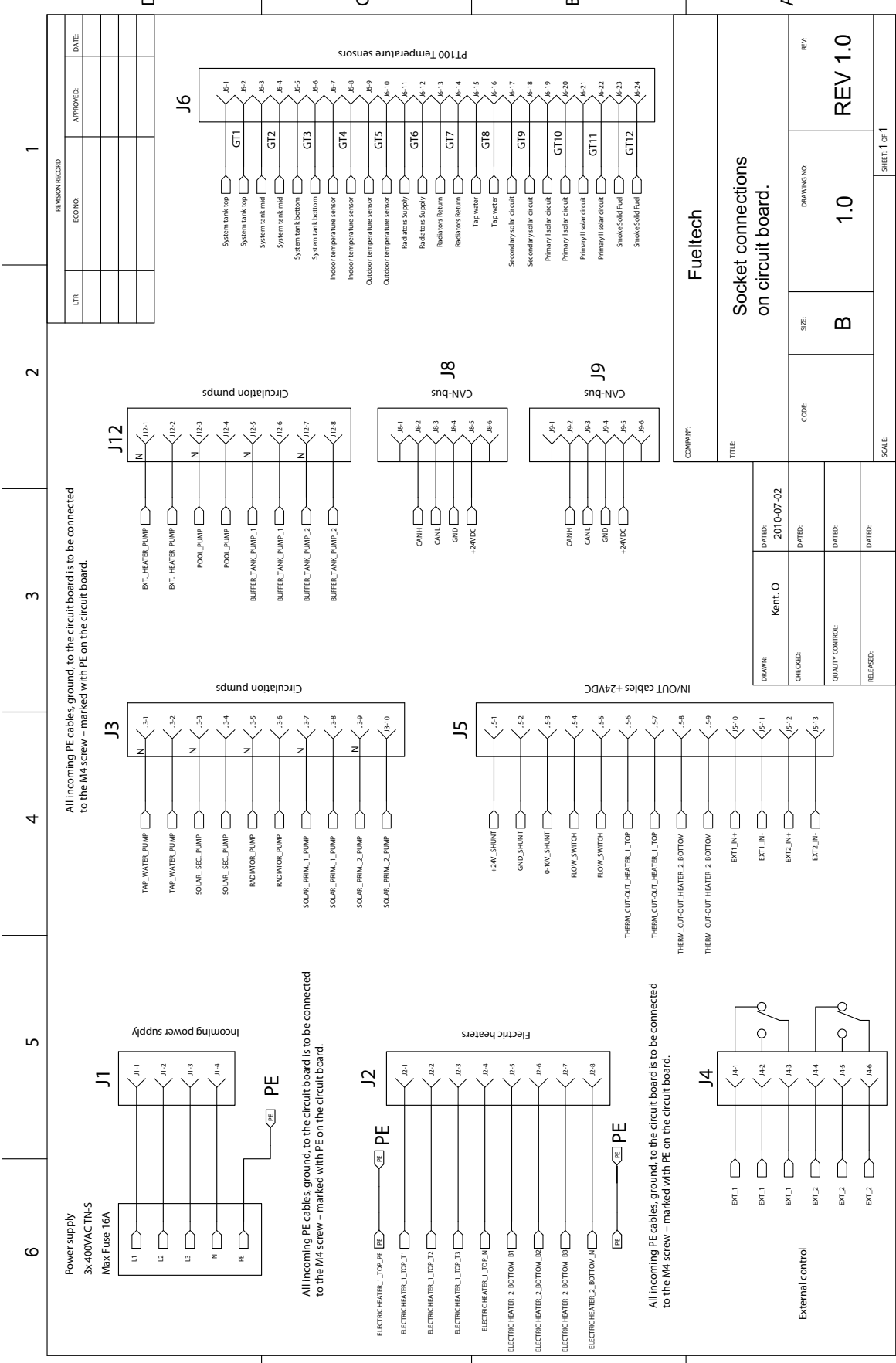

All incoming PE cables, ground, to the circuit board is to be connected to the M4 screw – marked with PE on the circuit board.

All incoming PE cables, ground, to the circuit board is to be connected to the M4 screw – marked with PE on the circuit board.

All incoming PE cables, ground, to the circuit board is to be connected to the M4 screw – marked with PE on the circuit board.



## Default settings

Module	Description	Default settings (standard value)											
Heating	Solid fuel – middle of system tank	Start at 50°C					Stop at 52°C						
	Electric heater 1 – top of system tank	Start at 58°C					Stop at 72°C						
	Electric heater 2 – middle of system tank	Start at 58°C					Stop at 72°C						
	Max temperature in tank – top of system tank	90°C											
Solar circuit	Secondary circuit start delay	30 seconds											
	Primary circuit tolerance	4°C											
	Temperature measuring interval, secondary circuit	2 minutes											
	Temperature measuring duration, secondary circuit	30 seconds											
	Secondary circuit tolerance	2°C											
	Primary circuit max. temperature	90°C											
	Primary circuit min. temperature	-20°C											
	Cooling duration, primary circuit	60 seconds											
	Seasonal settings: February - April	To: 9 am 9						Cut-off: 5°C					
		From: 5 pm 17						Duration: 60 minutes					
	May - July	To: 2 am 2						Cut-off: 5°C					
		From: 10 pm 22						Duration: 60 minutes					
	August - October	To: 10 am 10						Cut-off: 5°C					
		From: 6 pm 18						Duration: 60 minutes					
Radiator circuit	Desired indoor temperature	20°C											
	Pump stop at outdoor temperature above	18°C											
	Min. temperature in circuit	20°C											
	Max. temperature in circuit	65°C											
	Time for shunt to open	8 minutes											
	Radiator circuit temperature curve	18	23	28	33	38	43	46	48	50	53	54	
20		15	10	5	0	-5	-10	-15	-20	-25	-30		
Floor heating circuit	Desired indoor temperature	20°C											
	Pump stop at outdoor temperature above	18°C											
	Min. temperature in circuit	20°C											
	Max. temperature in circuit	45°C											
	Time for shunt to open	8 minutes											
	Floor heating circuit temperature curve	20	22	24	26	28	30	32	34	36	38	40	
20		15	10	5	0	-5	-10	-15	-20	-25	-30		

Figure 45. Default settings

## List of Components

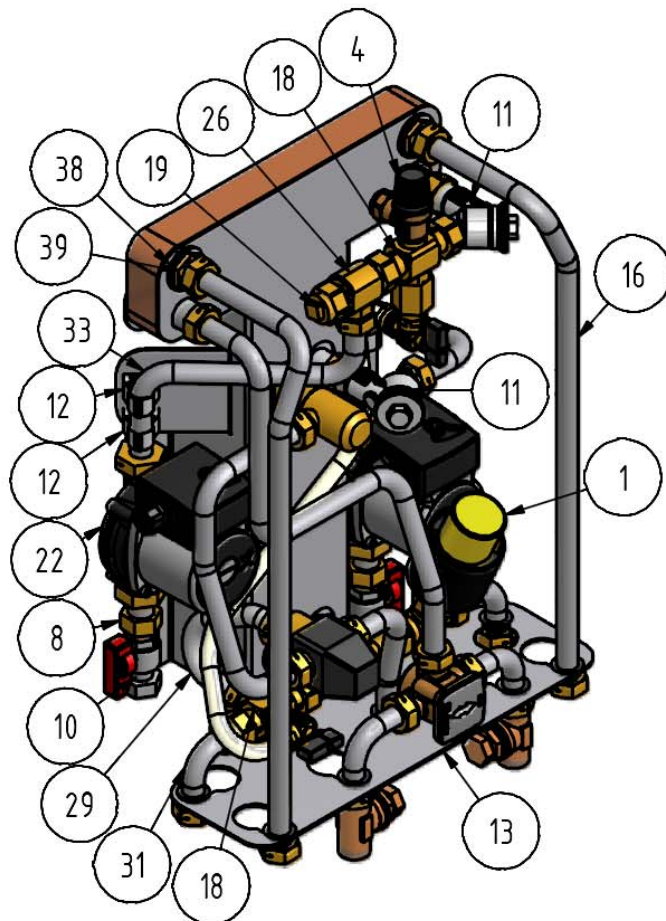
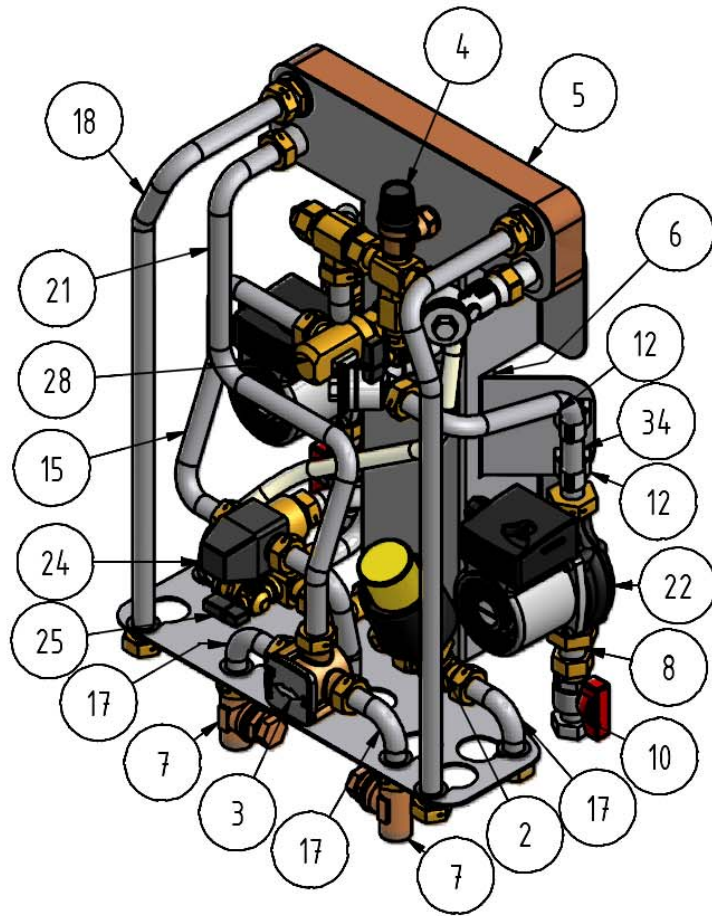

Pos			Qty
1	(Included in pos. 6)		1
2	Control Valve	DN15 Samson 2432N Kvs 2,5	1
3	3-way valve	Valve 6320A LK ACASO	1
4	Safety valve	1,5 Bar	1
5	Heat exchanger	CB20-20H	1
6	Heat exchanger	CB20IS-35H	1
7	Control valve	TA Trim K 3/4"	2
8	Brass part	Brass part 1	4
9	Strainer	Brass part, angle	2
10	Shut off valve	3/4" In_Out	2
11	Strainer	3/4" Out, 90 degrees angle	1
12	Clamp	Galvanized steel, 16-20mm	4
13	Frame	Galvanized steel	1
14	Pipe	Stainless steel, 18 mm	1
15	Pipe	Stainless steel, 18 mm	1
16	Pipe	Stainless steel, 18 mm	1
17	Pipe	Stainless steel, 18 mm	1
18	Brass part	Multi connection 1	1
19	Brass part	Plug	3
20	Pipe	Stainless steel, 18 mm	1
21	Pipe	Stainless steel, 18 mm	1
22	Circular Pump	UPS 15-40-130, turned 270 degrees	1
23	Brass part	3/4" x 22, 726619 LK-Armatur	7
24	Pipe	Stainless steel, 18mm	1
25	Filling valve	90 degrees angle	2
26	Brass part	Multi connection 2	1
27	Brass part	Out G3/4" In G1/2" with O-ring sealing	1
28	Flow switch	Henke-Sass	1
29	Pipe	Stainless steel, 18mm	1
30	Non return valve	DN15	1
31	Pipe	Stainless steel, 18mm	1
33	Pipe	Stainless steel, 18mm	1
34	Pipe	Stainless steel, 18mm	1
35	Hose	Nylon-hose 15 x 19 x 110 mm	1
36	Gasket	3/4"	22
38	Washer	D24-40 mm (T=3 mm)	4
39	Brass part	Nut 3/4" low (T=6 mm)	4
40	Circular pump	UPS 15-60-130, turned 90 grader	1

